



Installation Instruction

SEARCHLIGHTS

**for AIRBUS helicopters
BK117-C2 and BK117-D2, -D3 (EC145 & H145)**

www.aveoengineering.com

TABLE OF CONTENTS

PART 0	MANUAL ADMINISTRATION	3
0.1	DOCUMENT APPROVAL	3
0.2	AMENDMENT RECORD PROCEDURE	4
0.3	AFFECTED PAGES PROCEDURE	4
PART 1	INSTALLATION INSTRUCTION	5
1.1	GENERAL	5
1.2	CONTINUED AIRWORTHINESS	5
1.3	AIRWORTHINESS LIMITATIONS	5
1.4	DESCRIPTION	6
1.4.1	SEARCHLIGHTS	6
1.5	SEARCH LIGHTS INSTALLATION	7
1.5.1	WIRING DIAGRAMS – BK117-C2 (EC145)	12
1.5.2	WIRING DIAGRAMS – BK117-D2, D3 (H145)	15
1.5.3	WIRING DIAGRAMS – BK 117 D3, D3M	18
1.6	WIRING CHANGE IF NECESSARY (E.G. REPLACEMENT OF GOODRICH LIGHTS)	21
PART 2	COMPLIANCE DEMONSTRATION	23

Part 0 Manual Administration

0.1 Document Approval

This document has been established in accordance with an alternative procedure to DOA approved under EASA AP429.

This Installation Instruction is applicable for the following **Airbus helicopter** models:
Airbus BK117, H145 (EC145).

Compiled by:  _____ 20 August 2024
Petr Jaros
Engineer, Aveo Engineering Group, s.r.o.

Approved by: _____ 20 August 2024
Georg Hartl
Head of DO, Aveo Engineering Group, s.r.o.

0.2 Amendment Record Procedure

The master copy of this document shall be kept electronically as a read only document under the control of Aveo Engineering Group, s.r.o. as Master Copy.

ALL amendments to this manual will initiate a raise of issue.

The original issue will be identified by "**01**", and subsequent issues will be numbered sequentially from 02 to 99 in Table 01 - **Issue No.** column.

ALL issues of this document will be approved by Head of DO.

Issue No.	Details	Date	Affected Pages
01	Initial Issue	8. Mar. 2019	ALL
02	Editorial change	10. Mar. 2019	-
03	Addition of helicopter versions BK117 D-3, D-3m Addition of more versions to the lights Luminator LS400, Aveo Sapphire and Omega Addition of wiring change	20. Jun. 2021	6 6 ff 27
04	Removed OMEGA and LS400 lights, added new part numbers for S46 and S64 search light.	20 August 2024	ALL

Table 01: Record of Document Amendments

0.3 Affected Pages Procedure

ALL pages affected by ANY raise of issue of this document will be listed in Table 01 - **Affected Pages** Column.

Changes from the previous issue are shown as follows:

- a) new text is highlighted with yellow shading: **new**
- b) deleted text is shown with yellow shading and a strike through: ~~deleted~~

Part 1 Installation Instruction

1.1 General

This installation is to be performed in accordance to common practice as described in *Advisory Circulars of FAA Regulations*:

- FAR AC 43.13-2B Chapter 4
- FAR AC 43.13 1B Chapter 11 Section 15 (Bonding)

and in general practice section of the **Airbus H145 (EC145) Aircraft Maintenance Manual (AMM)**.

The installer is responsible to follow the installation instructions in the latest revision of the following *installation manuals*:

- AVE-SLSA46-IM
- AVE-SLSA64-IM

All drawings applicable for this change are listed in the Drawing List:

- None

The change is to be performed using the document AVE-MOD-023-MCS in the latest issue.

The aircraft modified according to this instruction may not be released back to service without the EASA design approval certificate being provided.

1.2 Continued Airworthiness

The aircraft manuals remain fully valid. The inspection intervals and the procedures of the aircraft override the general statements in the component manuals as listed under §1.1.

For inspection of the new lights themselves follow the procedure of the Aveo Installation Manuals referenced above.

1.3 Airworthiness Limitations

No new or changed airworthiness limitations result from this modification.

The airworthiness limitation section is approved and variations must also be approved.

1.4 Description

This modification rests in the replacement of searchlight and retractable landing light with lights of LED type.

The BK117 C-2 and BK117 D-2, BK117 D-3, BK117 D-3m (EC145 & H145) helicopter can be equipped with a search light or a retractable landing light. Searchlight and retractable landing light can both be retracted but in addition to that the search light can be rotated around the vertical axis (extended position) while the direction of the landing light is fixed.

Both lights are additional options to the customer and therefore not required to fly the helicopter in night operation as the helicopter is also equipped with a landing light fix installed in the cowling or in the lower fairing panels. These required landing lights are not affected by this modification.

In this modification we only offer the searchlight. In case a retractable landing light was installed before, is the vertical axis of the searchlight not connected to the helicopter controls.

1.4.1 Searchlights

Two options are available for installation of searchlights.

Aveo Sapphire 46 can be operated:

- either in a **single mode** – visible,
 - or in a **dual mode** – visible or infrared,
 - or in a **warpspeed dual mode** – visible or infrared.
- **Aveo Sapphire S46** - is a 360 degree, full swiveling, single- or dual-mode searchlight available with different deployment angles controlled by firmware and mechanical limitations.
Aveo added a dual version with an additional dimming function, versions with increased intensity (Warpspeed) and all versions with a stronger mechanic for increased operational speeds (up to 250 Knots).
 - **Aveo Sapphire S64** - is a 360 degree, full swiveling, single- or dual-mode searchlight available with different deployment angles controlled by firmware and mechanical limitations.
Aveo added a dual version with an additional dimming function, versions with increased intensity (Warpspeed) and all versions with a stronger mechanic for increased operational speeds (up to 220 Knots).

1.5 Search Lights Installation

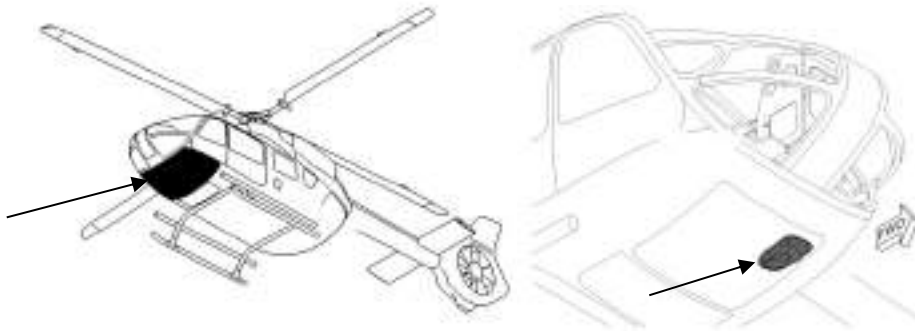

Option A-1 - Searchlight (Sapphire S46)

Kit Number: ARBS-01
ARBS-02
ARBS-03
ARBS-04

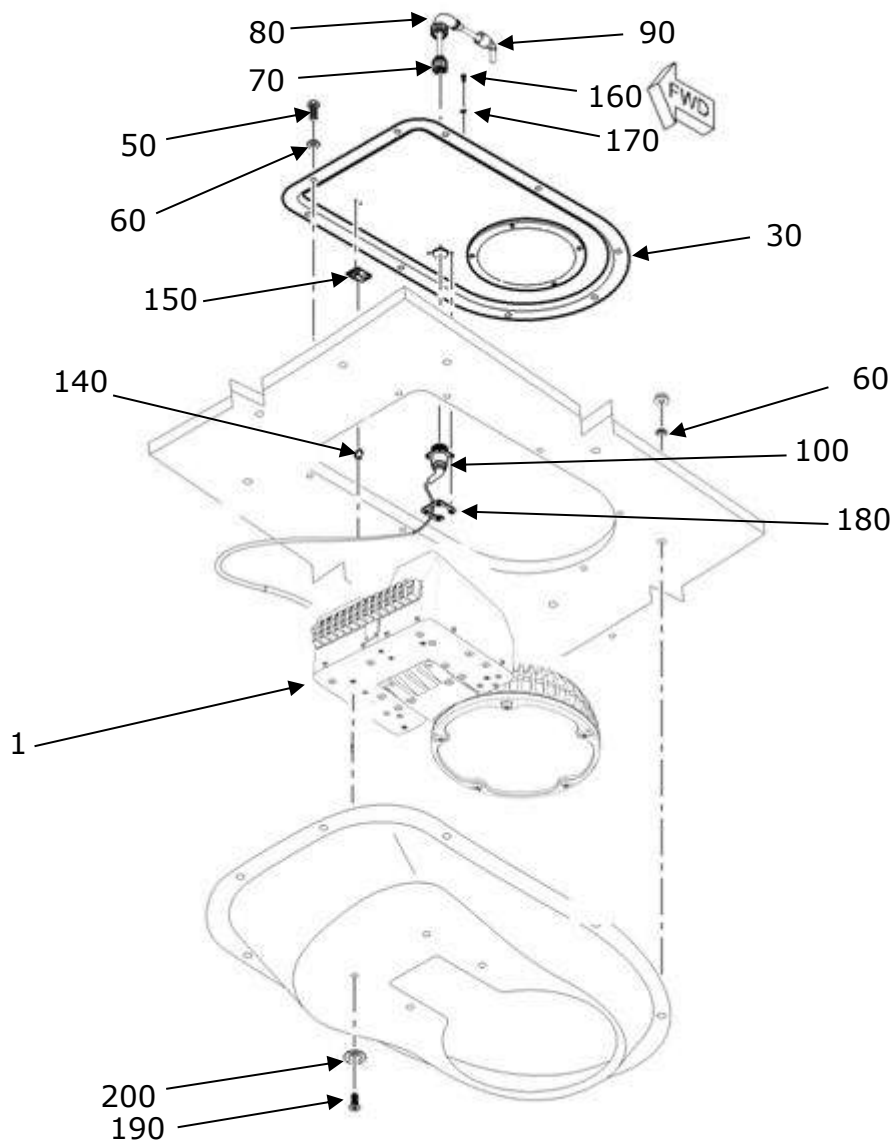

Option A-2 – Searchlight (Sapphire S46)

Kit Number: ARBS-05
ARBS-06
ARBS-07
ARBS-08
ARBS-09

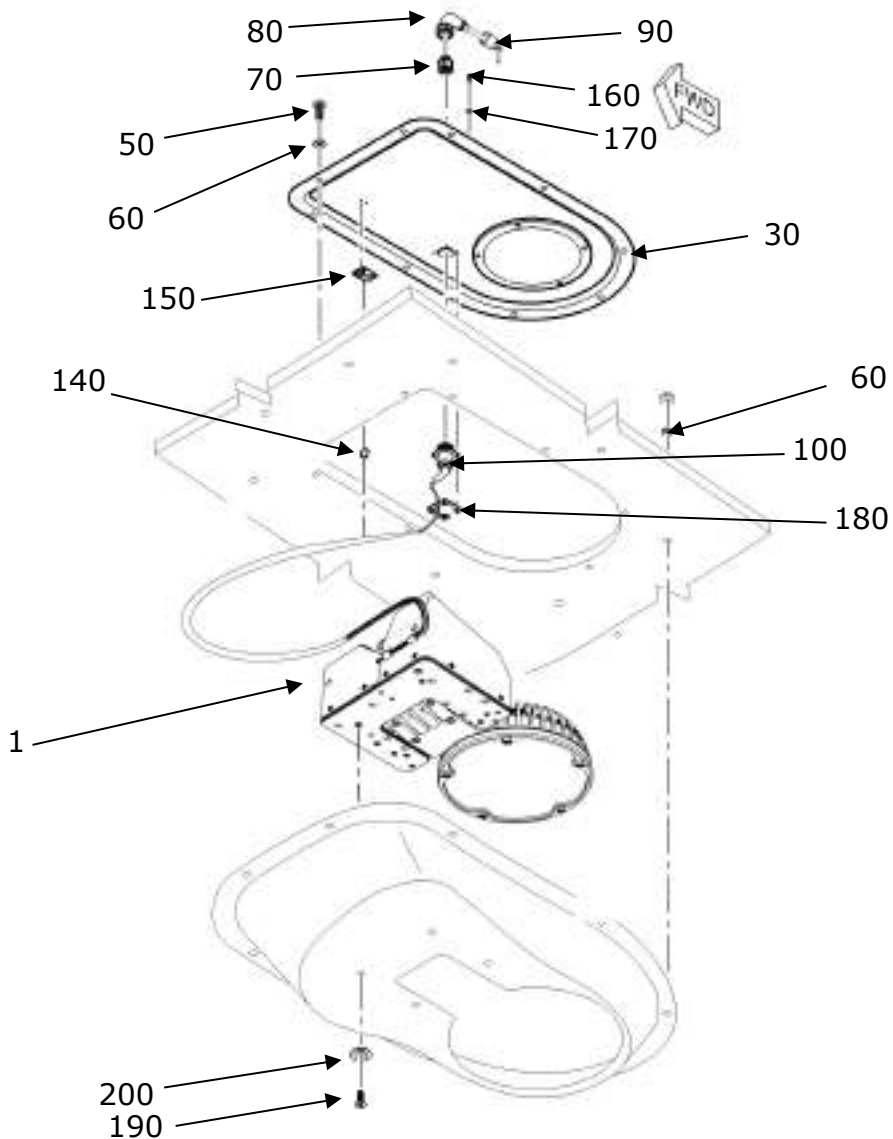

Option A-3 – Searchlight (Sapphire S64)

Kit Number: **ARBS-10**
ARBS-11
ARBS-12
ARBS-13
ARBS-14
ARBS-15

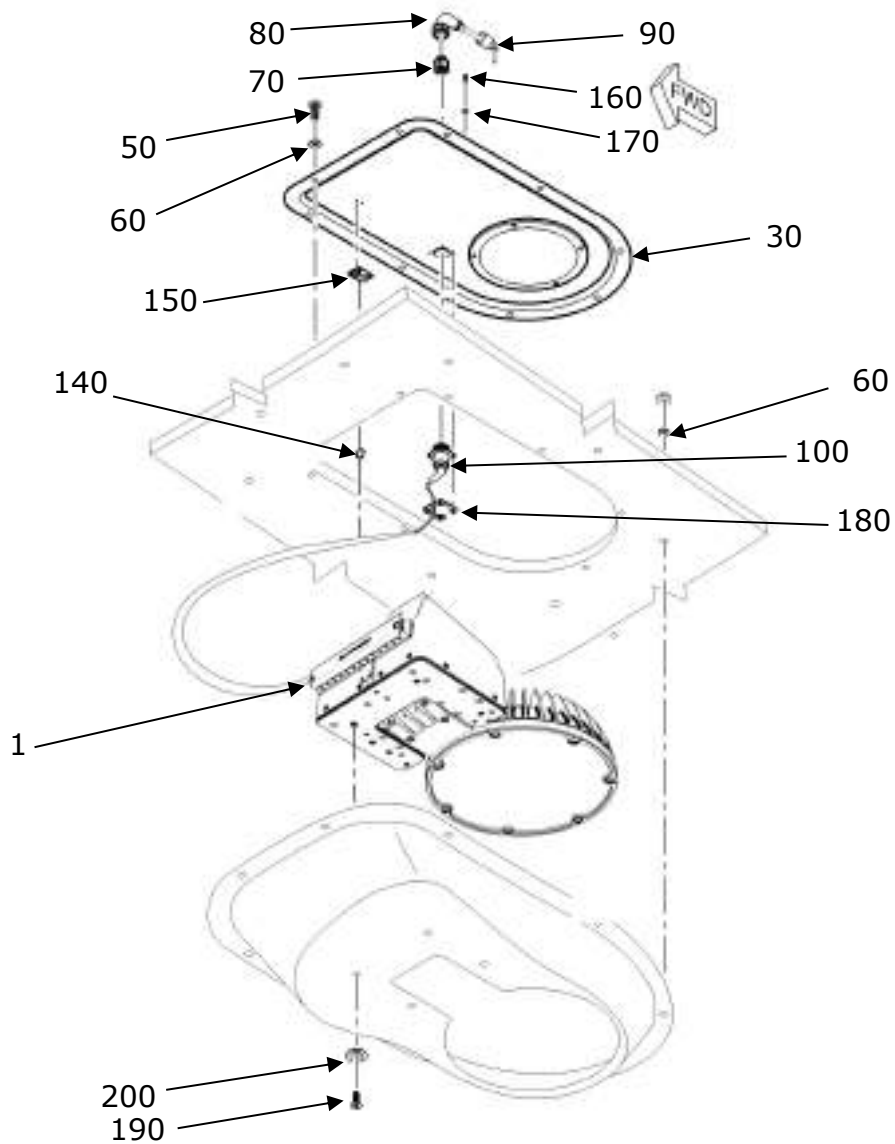

FIGURE AND INDEX NUMBER	PART NUMBER	DESCRIPTION	Kit NUMBER	QTY PER ASSY
Option A				
1	AVE-SLSA46W-M21	Sapphire S46	ARBS-01	1
	AVE-SLSA46WI-M21	Sapphire S46 Dual	ARBS-02	1
	AVE-SLSWA46W-M21	Sapphire S46 Warpspeed	ARBS-03	1
	AVE-SLSWA46WI-M21	Sapphire S46 Warpspeed Dual	ARBS-04	1
Option B				
1	AVE-SLSA46W-M21.1	Sapphire S46 Dual	ARBS-05	1
	AVE-SLSA46W-M21.1 Mod(1)	Sapphire S46 Dual	ARBS-06	1
	AVE-SLSWA46W-M21.1	Sapphire S46 Warpspeed	ARBS-07	1
	AVE-SLSWA46WI-M21.1	Sapphire S46 Warpspeed Dual	ARBS-08	1
	AVE-SLSWA46WI-M21.1 Mod(1)	Sapphire S46 Warpspeed Dual	ARBS-09	1
Option C				
1	AVE-SLSA64W-M10	Sapphire S64	ARBS-10	1
	AVE-SLSA64WI-M10	Sapphire S64 Dual	ARBS-11	1
	AVE-SLSA64WI-M10 Mod(1)	Sapphire S64 Dual	ARBS-12	1
	AVE-SLSWA64W-M13.0	Sapphire S64 Warpspeed	ARBS-13	1
	AVE-SLSWA64WI-M13.0	Sapphire S64 Warpspeed Dual	ARBS-14	1
	AVE-SLSWA64WI-M13.0 Mod(1)	Sapphire S64 Warpspeed Dual	ARBS-15	1
-----	-----	<i>Original parts</i>	-----	-----
Options A,B,C				
30	D334M3060101	Inner Cover Assy Search & Landing Light (LH)		1

50	LN9038-05024	Screw	9
60	EN2914-05010	Washer	17
70	EN3645M6DN97BN	Connector MIL-C-38999 II (EQD 6720LSAA)	1
80	EN3660-062F15B	Backshell	1
90	VG95343T18B001A	Connector Endshell With	1
100	EN3645F0DN97AN	Connector, MIL-C-38999 III (EQD 6720LSA)	1
	EN3660-062F15B	Backshell	1
	VG95343T18B001A	Connector Endshell with	1
140	E0043-1A9P	Banding Clamp	1
150	TY8G1	Support	1
160	EN3308-030010F	Bot, Hex. Head	4
170	LN9016-03L	Washer	4
180	MBBN3332A16	Fixing Plate	1
190	NAS1102-08-7	Bolt, Shear-Hexagon	4
200	EN3835-040	Washer	4

NOTES

1. Remove the original light from helicopter according to AMM.
2. Inspect the installation location for corrosion and, if necessary, repair according to the original structural repair manual.
3. Install the new Aveo light by using original fasteners as listed and depicted above.
4. Connect the wiring by using the respective wiring diagram which is included in this document in accordance with the standard practice of the aircraft maintenance manual and if not specified there, then according to the common practice referenced in § 1.1. Use the original type of connector.

1.5.1 Wiring diagrams – BK117-C2 (EC145)
Original Installation

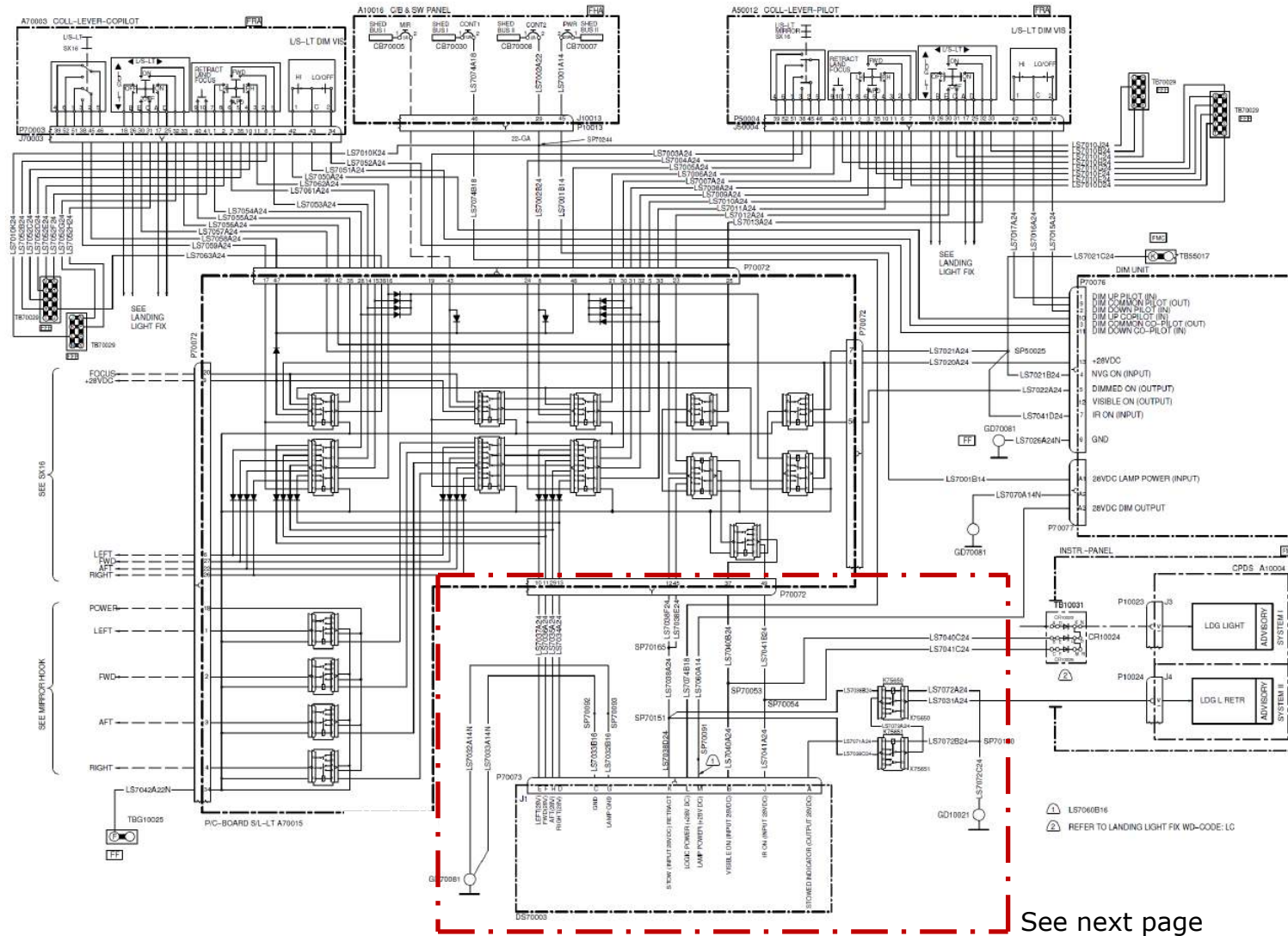

1.5.2 Wiring diagrams – BK117-D2, D3 (H145)
Original Installation

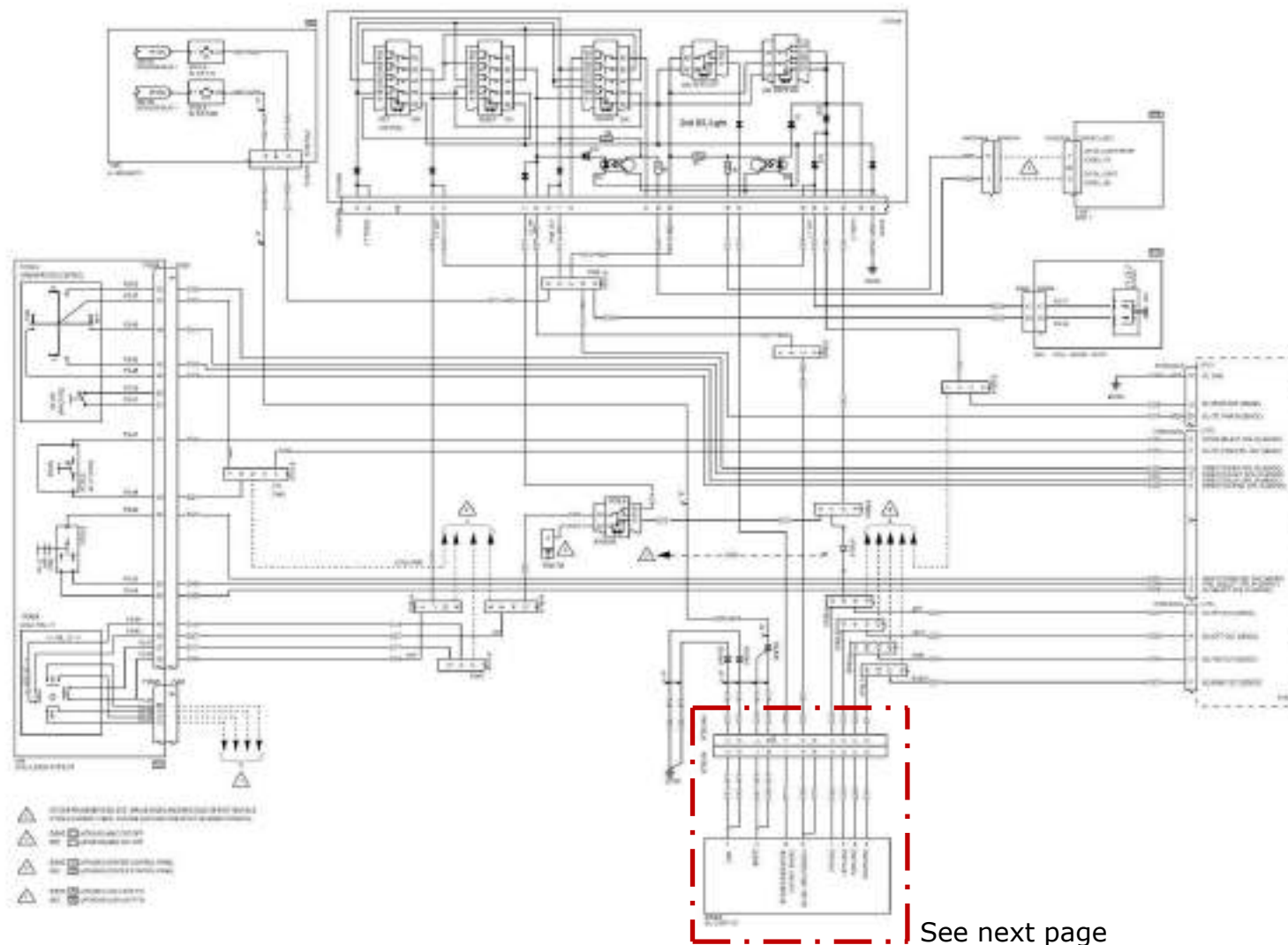

See next page

Original Installation – Detail

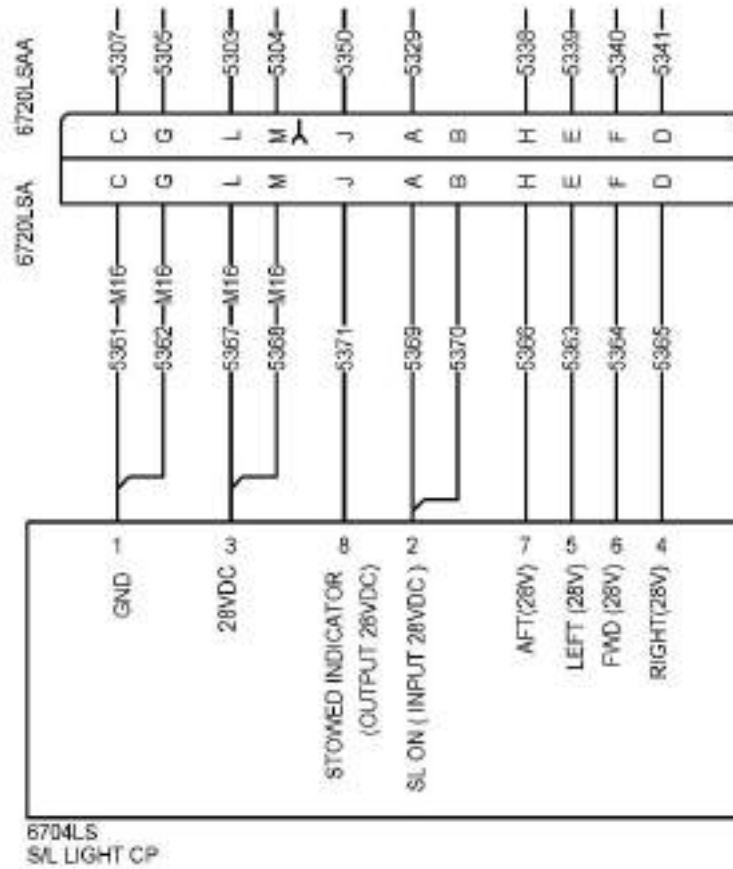

Installation Sapphire S46, S64

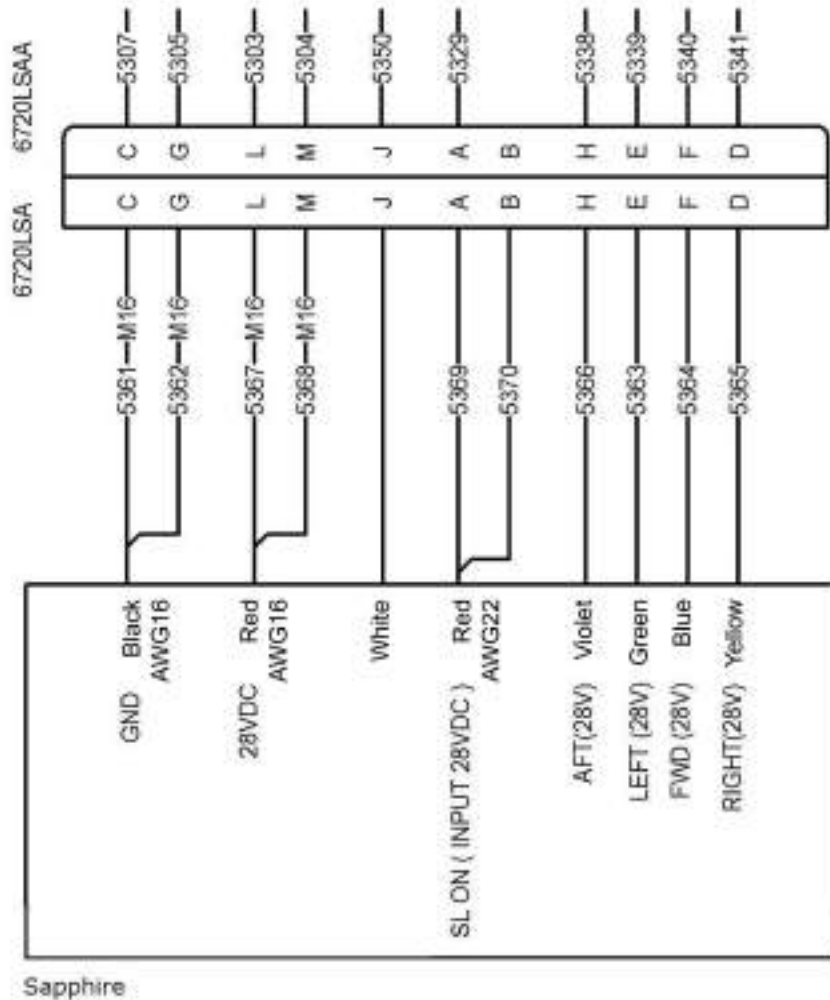

Note: For Dual Searchlight (vis/IR light) pin A is IR and pin B is visible white light 28V DC.

1.5.3 Wiring diagrams – BK 117 D3, D3m
Original Installation

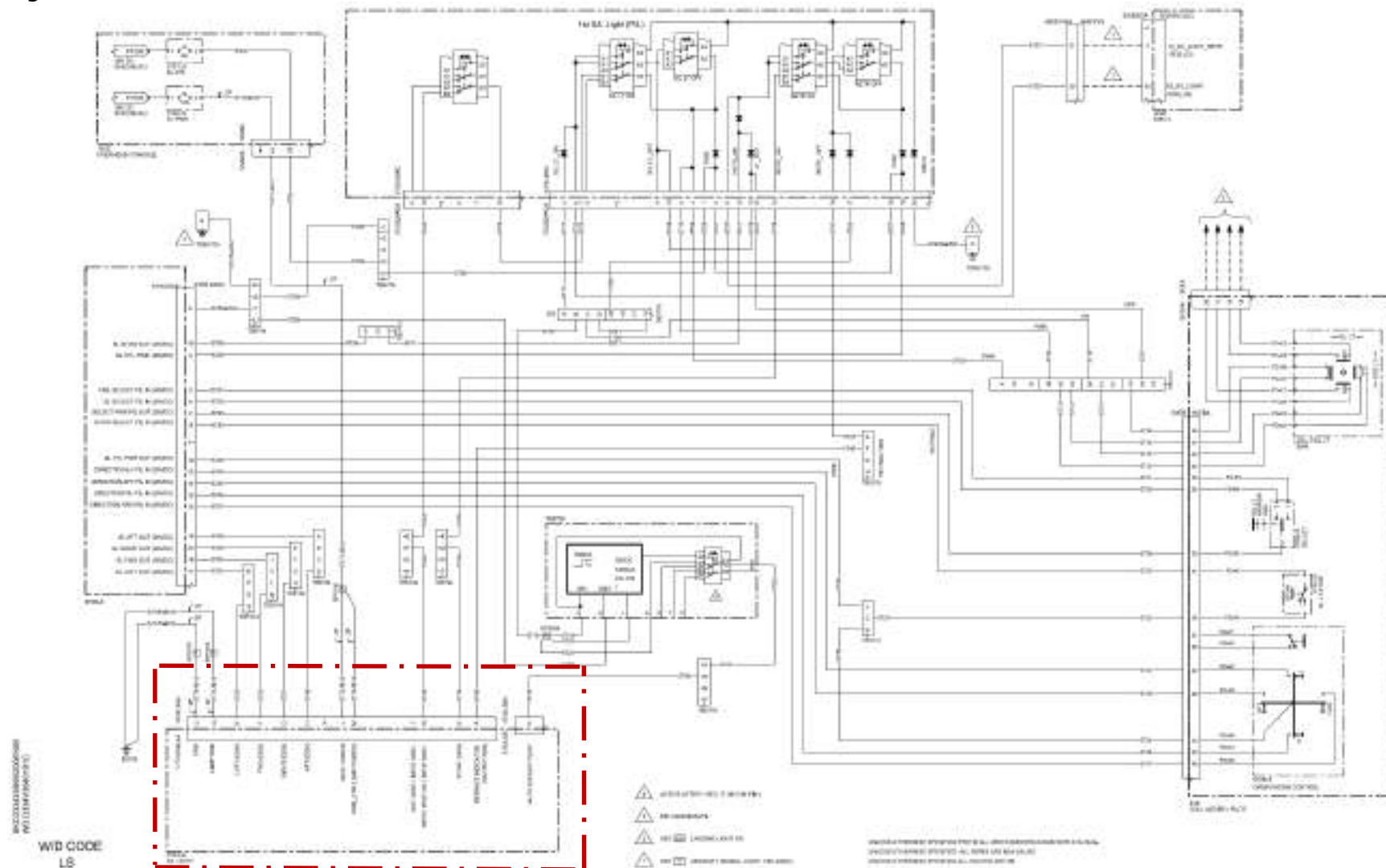

Original Installation - detail

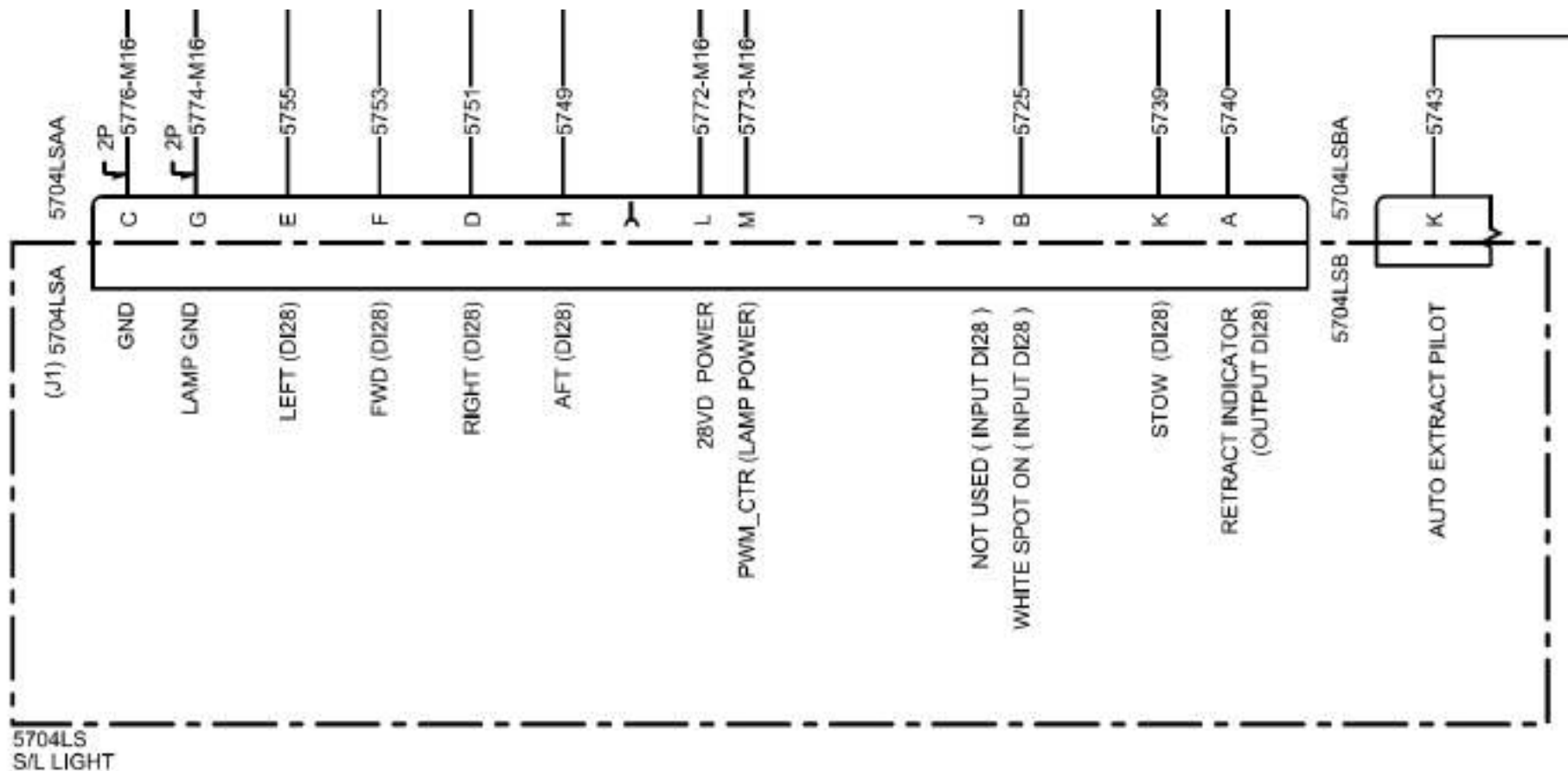

Installation Sapphire S46, S64

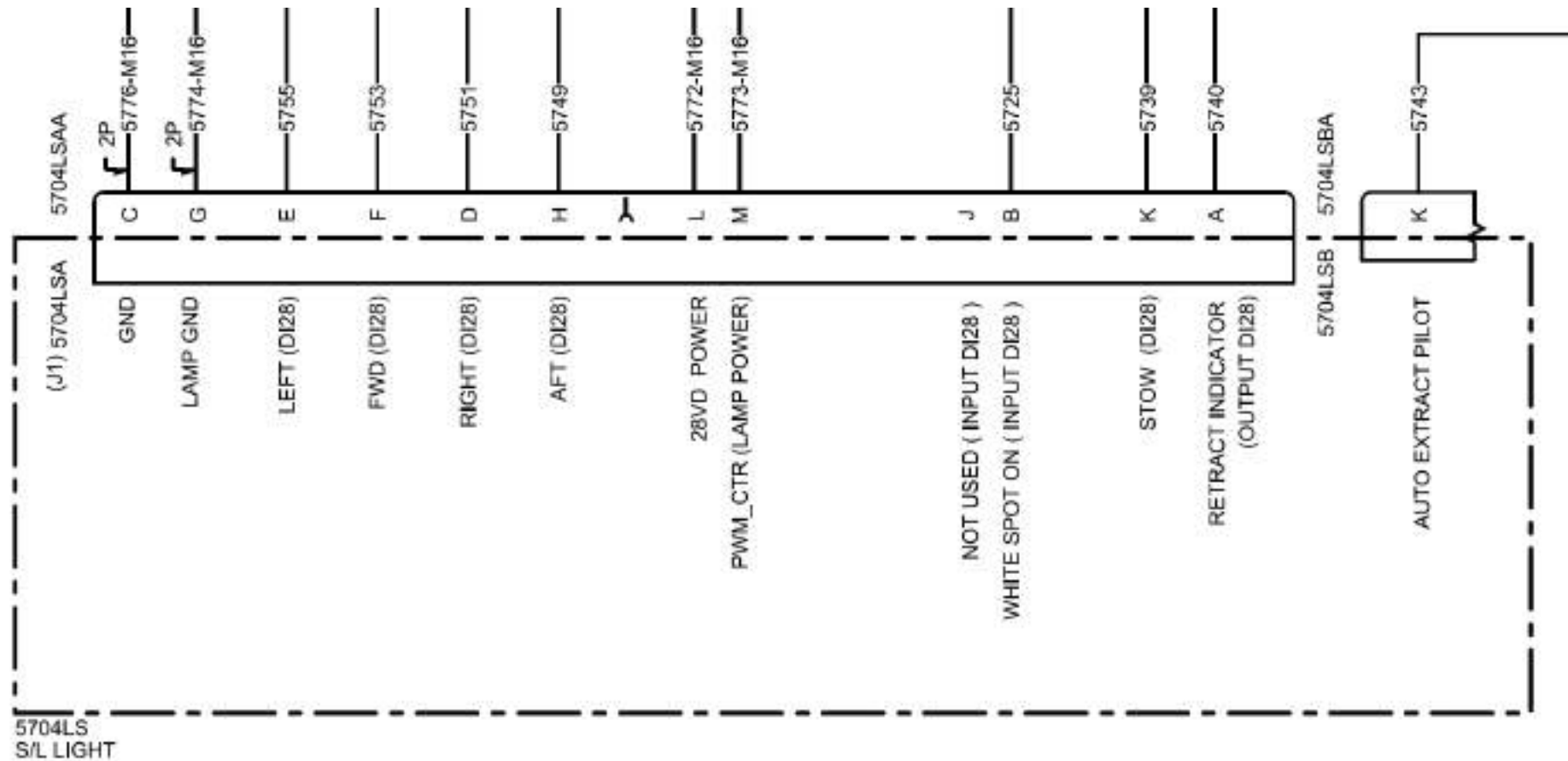

1.6 Wiring change if necessary (e.g. replacement of Goodrich lights)

The following are to be carried out (see wiring diagram next page):

1. 5702LS: REPLACE THE EXISTING 10A CIRCUIT BREAKER WITH A 15A CIRCUIT BREAKER.

APPLIES TO NOTES 2, 3 and 4 BELOW:

IF DIODES AND WIRES ARE NOT EXISTING; THEN INSTALL NEW DIODES; WIRES AND SPLICES AS SHOWN.

2. CONNECT DIODE 5712LS AS SHOWN.
DIODE 5712LS IS LOCATED BENEATH THE FLOOR, UNDER THE PILOT ROTOR BREAK HANDLE.
IF INSTALLING A NEW DIODE, THEN POSITION IT ON THE HARNESS NEAR RELAY 5711LSA.
3. CONNECT WIRE 3343-5256 M24 TO SPLICE SP5784, INSTALL AS SHOWN.
SP5784 IS LOCATED BENEATH THE FLOOR, RH SIDE OF PILOT CYCLIC; FWD OF ROTOR BREAK.
SP5784 IS LOCATED APPROX. 300mm FROM RELAY 5711LS.
4. CONNECT WIRE 3343-5223 M24 TO SPLICE SP5775, INSTALL AS SHOWN.
SP5775 IS LOCATED APPROX. 300mm FROM 66705LSAAA.
5. RELOCATE WIRE 3343-5232 M24 TO 5720LSAA PIN "A"
6. RELOCATE WIRE 3343-5238 M24 TO 5720LSAA PIN "J"
7. IF REQUIRED, REPLACE CONNECTOR 5720LSAAA HEAT SHRINKABLE BOOT.
PART NUMBER: VG95343T18B001A.

NOTE:

CONNECTOR 5720LSAAA CONTACT SERIES NUMBER IS EN3155-009.

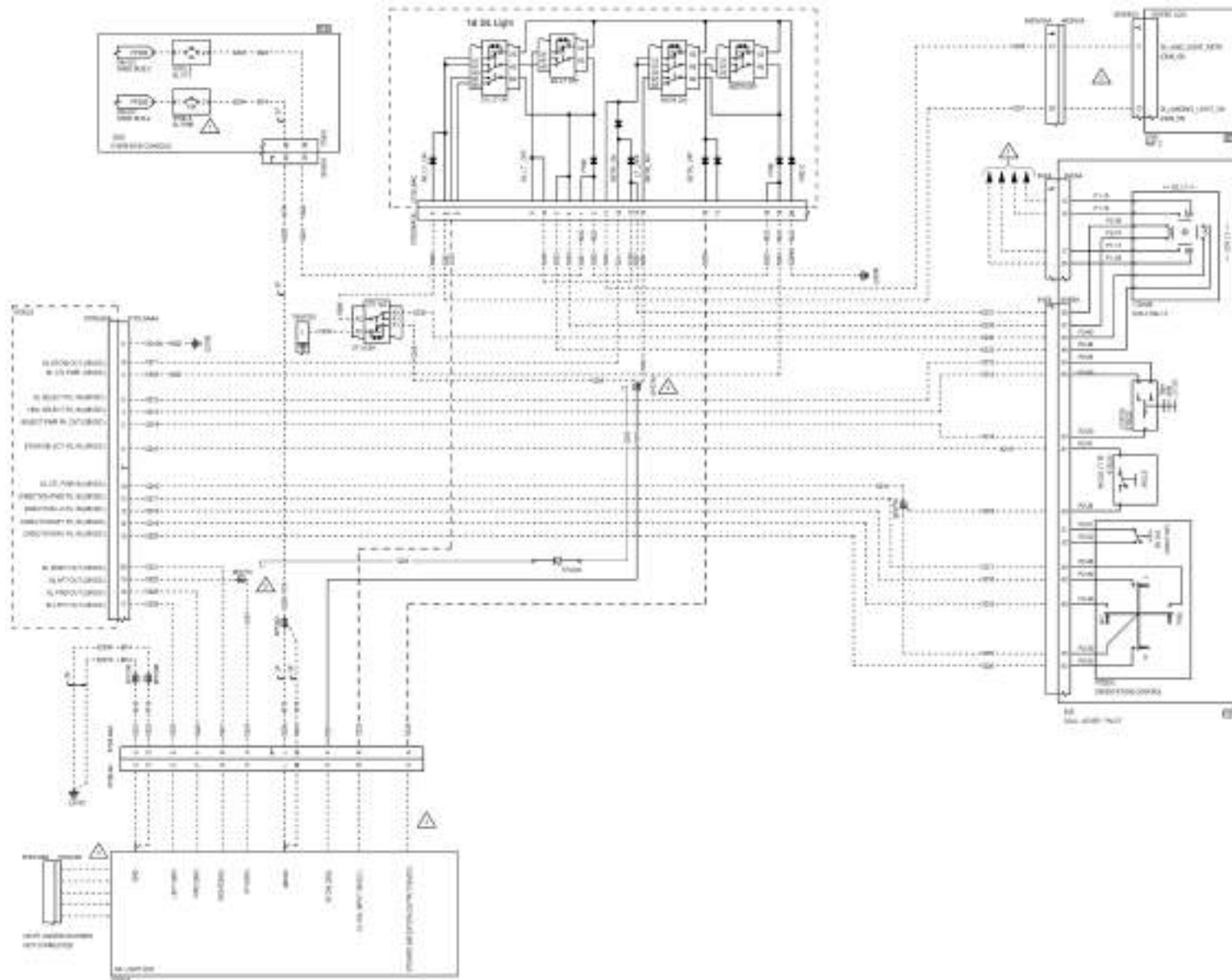

Part 2 Compliance Demonstration

This document is in relation to the certification program AVE-MOD-023-PFC.
 The compliance is demonstrated for the following certification specification:

Requirements	MoC	Statement of Compliance
CS 29.609 Protection of structure	MoC 0	(a) All parts installed are verified to be suitable. The installation instruction requests the aircraft structure to be inspected for probable corrosion before installing the new lights. (b) Not applicable
CS 29.1301 Function and installation	MoC 0	(a) The lights are based on the Aveo Samson added to the folding mechanism. The basics Samson light is qualified according to RTCA DO160 as per AVE-S45-CCL. (b) Not applicable as the function is as original installation. (c) All equipment is installed within their limits. (d) The proper function is determined in a ground check as per MCS.
CS 29.1383 Taxi and landing lights	MoC 0	(a)The configuration of the original installation is not changed. (b)(1) and (2) are not affected as the installation is not changed. (3) is improved as the new lights are brighter than the originally installed. (c) The landing light switches and the landing light configuration are not modified.
CS 29.1529 Instructions for Continued Airworthiness	MoC 0	The modification does not require any changes to the aircraft maintenance procedure which is clearly stated in §1.2 Continued Airworthiness.