



Installation Instruction  
**CESSNA**  
**T303 Crusader**

---

**Table of Contents**

<b>PART 0</b>	<b>MANUAL ADMINISTRATION</b>	<b>3</b>
0.1	DOCUMENT APPROVAL	3
0.2	AMENDMENT RECORD PROCEDURE	4
0.3	AFFECTED PAGES PROCEDURE	4
<b>PART 1</b>	<b>INSTALLATION INSTRUCTION</b>	<b>5</b>
1.1	GENERAL	5
1.2	CONTINUED AIRWORTHINESS	5
1.3	DESCRIPTION	5
1.4	WING POSITION LIGHTS INSTALLATION	6
1.5	REAR POSITION LIGHT INSTALLATION	9
1.6	ANTI-COLLISION LIGHTS INSTALLATION	11
1.7	TAXI LIGHT INSTALLATION – NOSE GEAR	13
1.8	LANDING LIGHTS INSTALLATION	15
<b>PART 2</b>	<b>COMPLIANCE DEMONSTRATION</b>	<b>17</b>

## **Part 0 Manual Administration**

### **0.1 Document approval**

This document has been established in accordance with an alternative procedure to DOA approved under EASA AP429.

This installation Instruction is applicable for the Cessna model T303 Crusader.

Compiled by:  \_\_\_\_\_ 22. – Jan. - 2020  
Petr Jaros  
Engineer, Aveo Engineering Group, s.r.o.

Approved by: \_\_\_\_\_ 22. – Jan. - 2020  
Georg Hartl  
Head of DO, Aveo Engineering Group, s.r.o.

## 0.2 Amendment Record procedure

The master copy of this document shall be kept electronically as a read only document under the control of Aveo Engineering Group, s.r.o. as Master Copy.

**ALL** amendments to this manual will initiate a raise of Issue

**ALL** raises of issue will be given a sequential Alphabetic Issue Ident sequentially from 01 to 99 in Table 01 - **Issue No:** Column- Initial Issue of Document will be "01"

**ALL** Issues of this document will be approved by Head of DO

Issue No.	Details	Date	Affected Pages
01	Initial Issue	22.Jan.2020	ALL

**Table 01: Document Amendment Record Table**

## 0.3 Affected Pages Procedure

ALL pages affected by ANY raise of issue of this document will be listed in Table 01 - *Affected Pages* Column.

The reason(s) for ALL raise of issue and description of change due to raise of issue will be provided for ALL raises of issue in Table 01 - *Details* Column.

Changes from the previous issue are highlighted by **YELLOW HIGHLIGHTING** over new content. AND **YELLOW HIGHLIGHTING** AND **CROSSING OUT** of deleted content.

Example (**CROSSING OUT**)

## Part 1 Installation Instruction

### 1.1 General

This installation is to be performed in accordance to common practice as described in FAR AC 43.13-2B Chapter 4 and in FAR AC 43.13 1B Chapter 11 Section 15 (Bonding) as published by FAA.

The installer is responsible to follow the installation instructions in the latest revision of:

- FAR AC 43.13-2B Chapter 4
- FAR AC 43.13 1B Chapter 11 Section 15
- AVE-WPS-64G-IM
- AVE-PSPSYW-IM
- AVE-RBXP-001-IM
- AVE-H30-001-IM

All drawings applicable for this change are listed in the Drawing List:

- AVE-MOD-033-DL, issue 01

The following appliances carry an ETSO authorization:

- AVE-WPSR-64G & AVE-WPSG-64G – ETSOA 210.10053936
- AVE-RBXPR-001 – ETSOA 210.10055069
- AVE-PSPSYW-T01 – ETSOA 210.10068603

The change is to be performed using the document AVE-MOD-033-MCS in the latest issue.

The aircraft modified according to this instruction may not be released back to service without the EASA design approval certificate being provided.

### 1.2 Continued Airworthiness

The aircraft manuals remain fully valid. The inspection intervals and the procedures of the aircraft override the general statements in the component manuals as listed under §1.1.

For inspection of the new lights themselves follow the procedure of the Aveo Installation Manuals referenced above.

### 1.3 Description

This modification is the replacement of position lights (type I, II & III), anti-collision lights, strobe lights, taxi lights and the landing lights by LED type lights.

In general the lights are direct replacements and do not require any structural change on the A/C side. Only exemption may be additional attachment holes and installation of anchor nuts in the secondary bracket of the wingtip light installation. The changes in wiring are very minor and are described in this modification or are to be done according to referenced standard practice (e.g. change of connector).

### 1.4 Wing Position Lights Installation

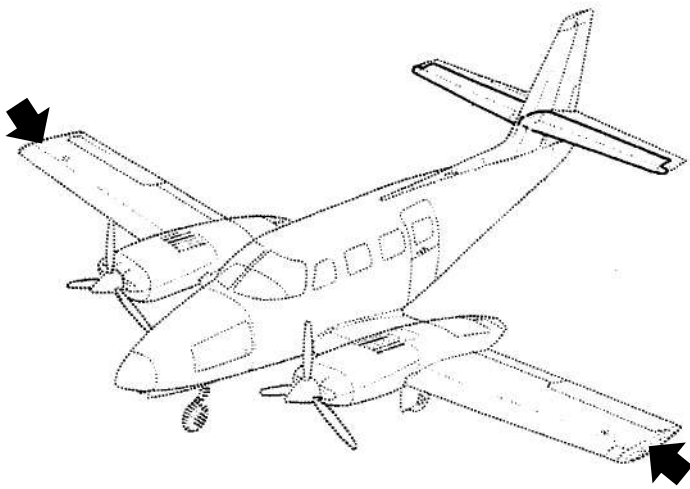

View A

Kit Number: C303-01

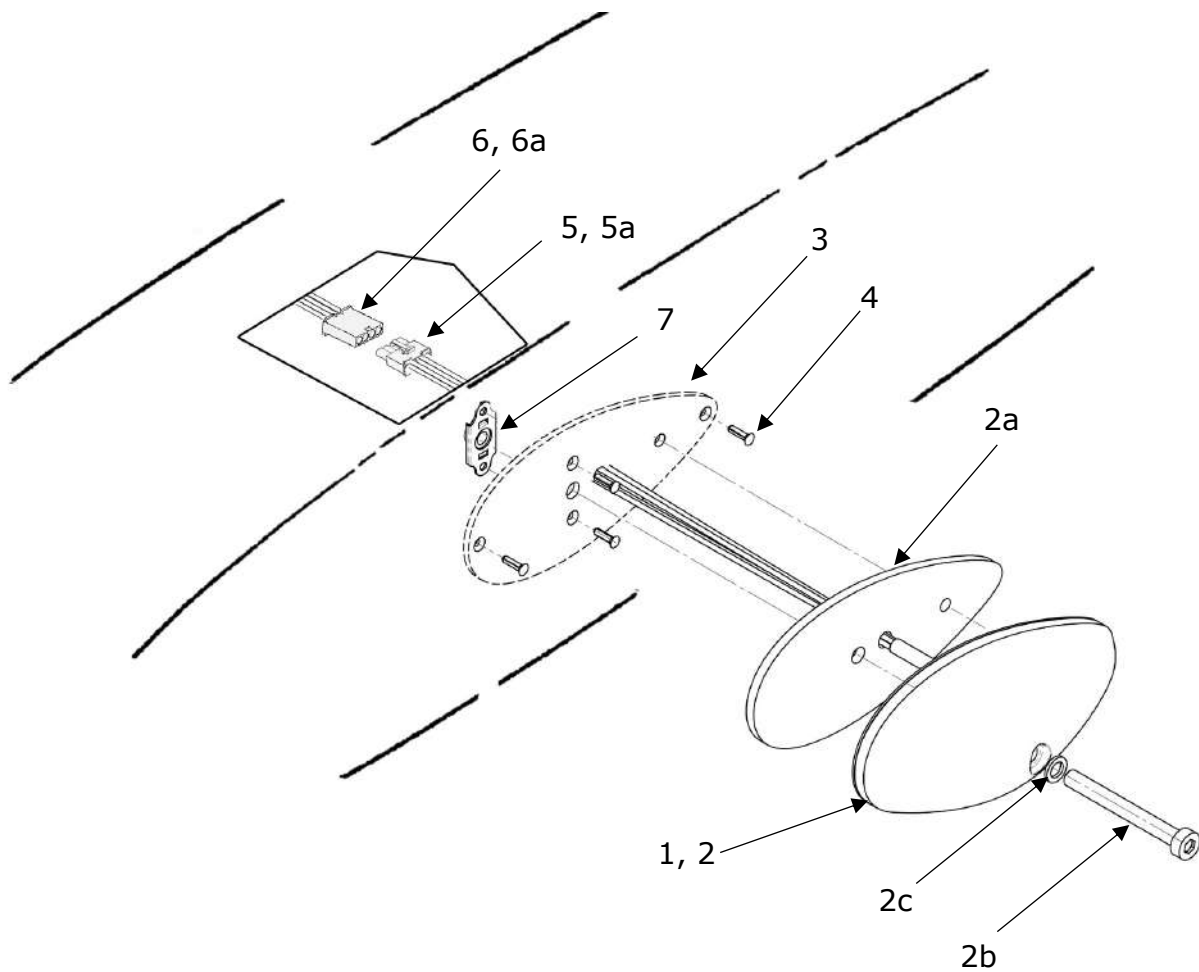

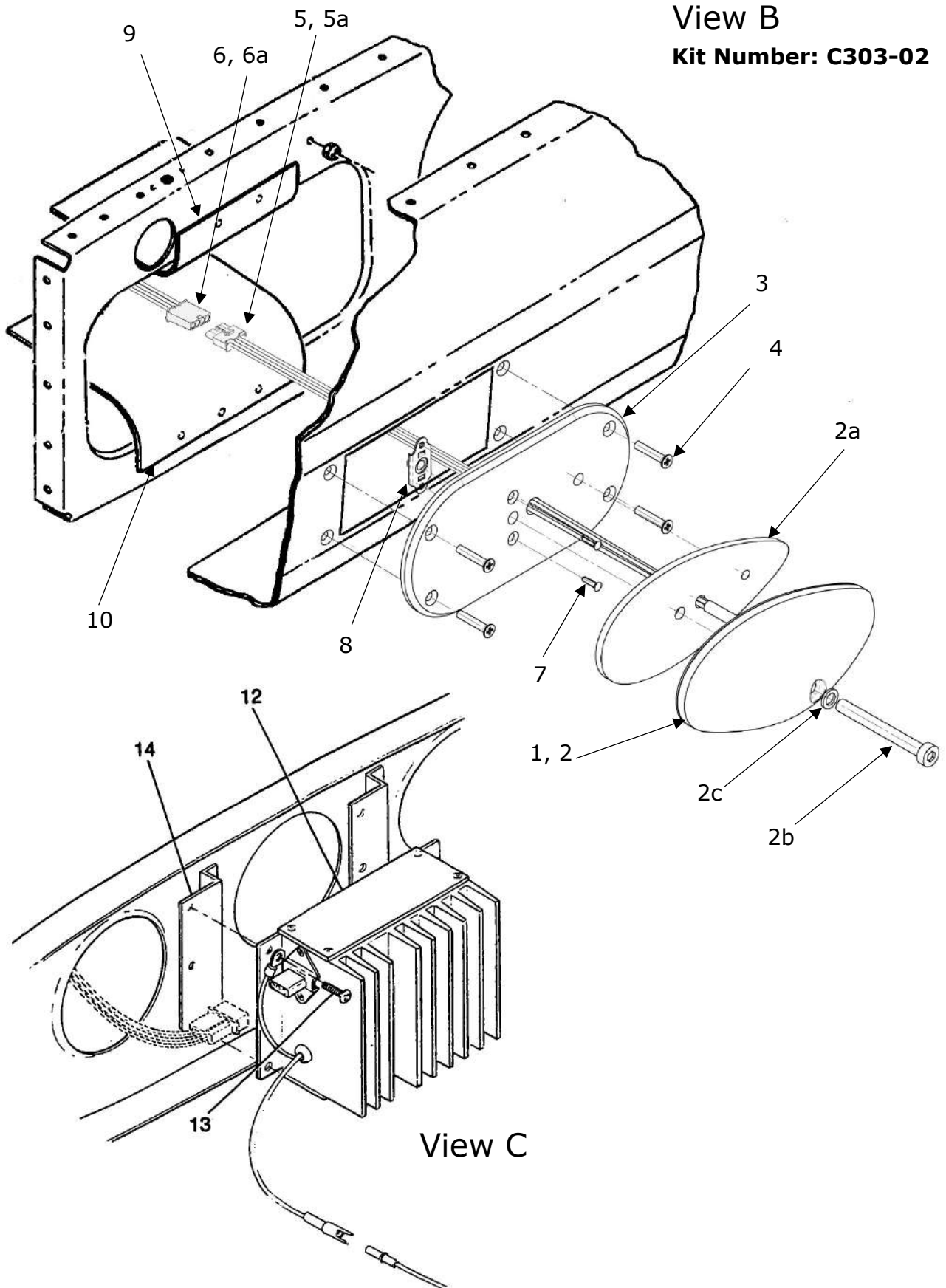

Figure and Index Number	Part Number	Description	Parts Avail.	QTY. Per assy.
View A		SERIAL T30300001 THRU T30300175		
1	AVE-WPSR-64G	Ultra Galactica Embedded Red		1
2	AVE-WPSG-64G	Ultra Galactica Embedded Green		1
2a	AVS-P001290550-A1A	Gasket		2
2b	AVS-79840905045	Screw M5x45mm		2
2c	AVS-OR00480190N70-D0A	O-ring		2
3	AVS-P00 0107407-A60	Ultra Adapter		2
4	AVS-6252408	Rivet 2.4x8mm		6
5	03091041	4-Pole Connector – Male		2
5a	2092116	Pin		8
6	03092041	4-Pole Connector - Female		2
6a	2091117	Socket		8
7	AVS-KFL-M5-080	Floating Riveting Nut		2
View B		SERIAL T30300176 AND ON		
1	AVE-WPSR-64G	Ultra Galactica Embedded Red		1
2	AVE-WPSG-64G	Ultra Galactica Embedded Green		1
2a	AVS-P001290550-A1A	Gasket		2
2b	AVS-79840905045	Screw M5x45mm		2
2c	AVS-OR00480190N70-D0A	O-ring		2
3	AVS-P00 01074078-A60	Ultra Adapter 1		2
4	AN507-632R8	Screw		6
5	03091041	4-Pole Connector – Male		2
5a	2092116	Pin		8
6	03092041	4-Pole Connector - Female		2
6a	2091117	Socket		8
7	AVS-6252408	Rivet 2.4x8mm		2
8	AVS-KFL-M5-080	Floating Riveting Nut		2
	-----	-----		-----
9	Original parts 2522408-1	Support-LH Upper		1
	2522408-2	Support-LH Lower		1
10	2522408-3	Support-RH Upper		1
	2522408-4	Support-RH Lower		1
View C	Original parts	STROBE BOX REMOVAL		
12	C622009-0101	Power Supply – Wing Strobe Light		2
13	AN520-10R7	Screw		4
14	2520017-1	Bracket Assy – Power Pack Attach		4

**NOTES**

1. Remove the light assemblies in accordance to the AMM.
2. Disconnect the wire bundle from the position and the strobe light.
3. Remove upper and lower support (View B – items 9 and 10)
4. Inspect the installation area for corrosion and correct according to AMM if required.
5. Install bracket, item 3 as described, using the fastener of the strobe light installation, item 4. Pick up fastener location from aircraft.
6. Remove strobe light power supply according to AMM. Connect the wingtip position and strobe light unit as per schematics described in the manuals listed in §1.1.
7. Install the wingtip lights, items 1 and 2.

1.5 Rear Position Light Installation

Kit Number: C303-03

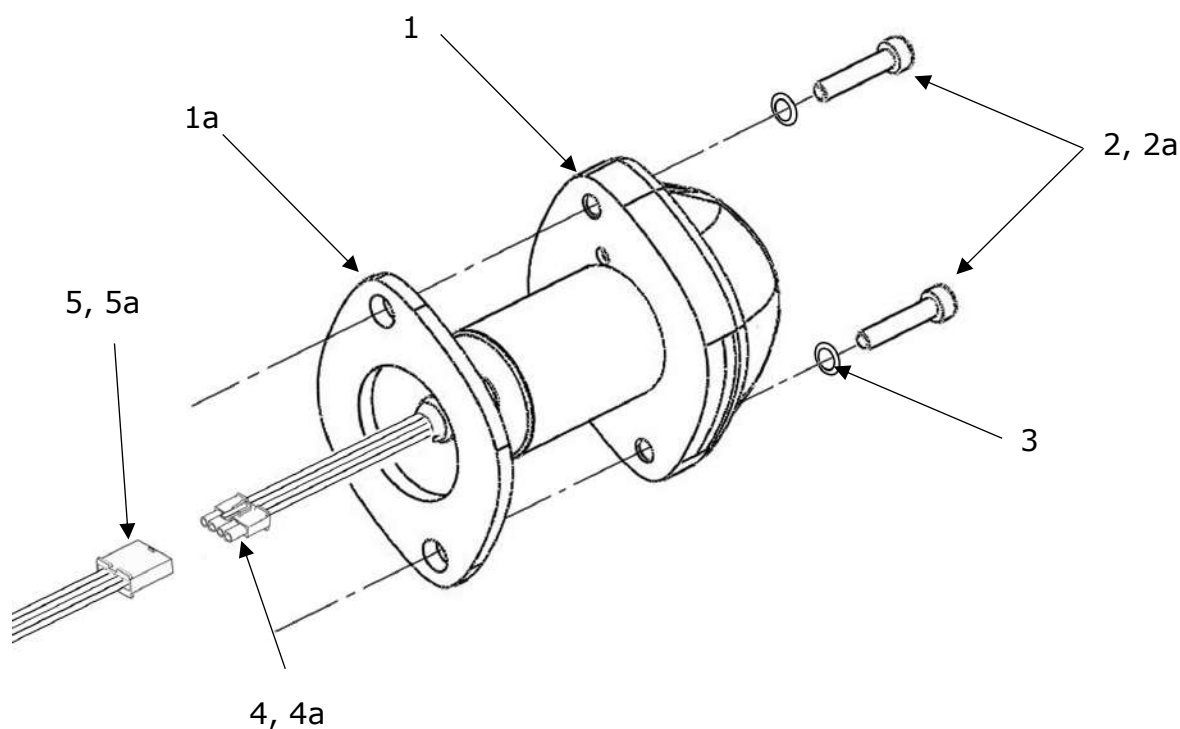
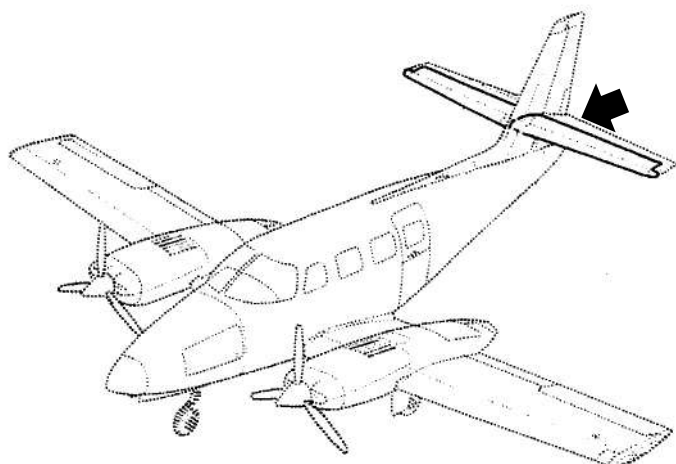

Figure and Index Number	Part Number	Description	Parts Avail.	QTY. Per assy.
1	AVE-PSPSYW-T01	PosiStrobe Titania		1
1a	AVS-P000105638-A10	Gasket		1
2	AVS-92196A150	Screw #6-32 Thread, 5/8" SHCS		2
2a	MS-16995-12	Screw #4-40 Thread, 5/8" SHCS		2
3	AVS-90295A359	Flat Washer – Nylon		2
4	03091041	4-Pole Connector – Male		1
4a	2092116	Pin		4
5	03092041	4-Pole Connector - Female		1
5a	2091117	Socket		4
NOTES				
<ol style="list-style-type: none"> <li>1. Remove position light in accordance to the aircraft maintenance manual.</li> <li>2. Disconnect the wire bundle from the position light</li> <li>3. Inspect the installation area for corrosion and correct according to AMM if required</li> <li>4. Connect the new light's wires into the bundle as described in the manuals referenced in §1.1 and common practice per FAR AC 43.13-2B Chapter 4</li> <li>5. Install item 1 to 4 as described.</li> </ol>				

1.6 Anti-collision Lights Installation

Kit Number: C303-04

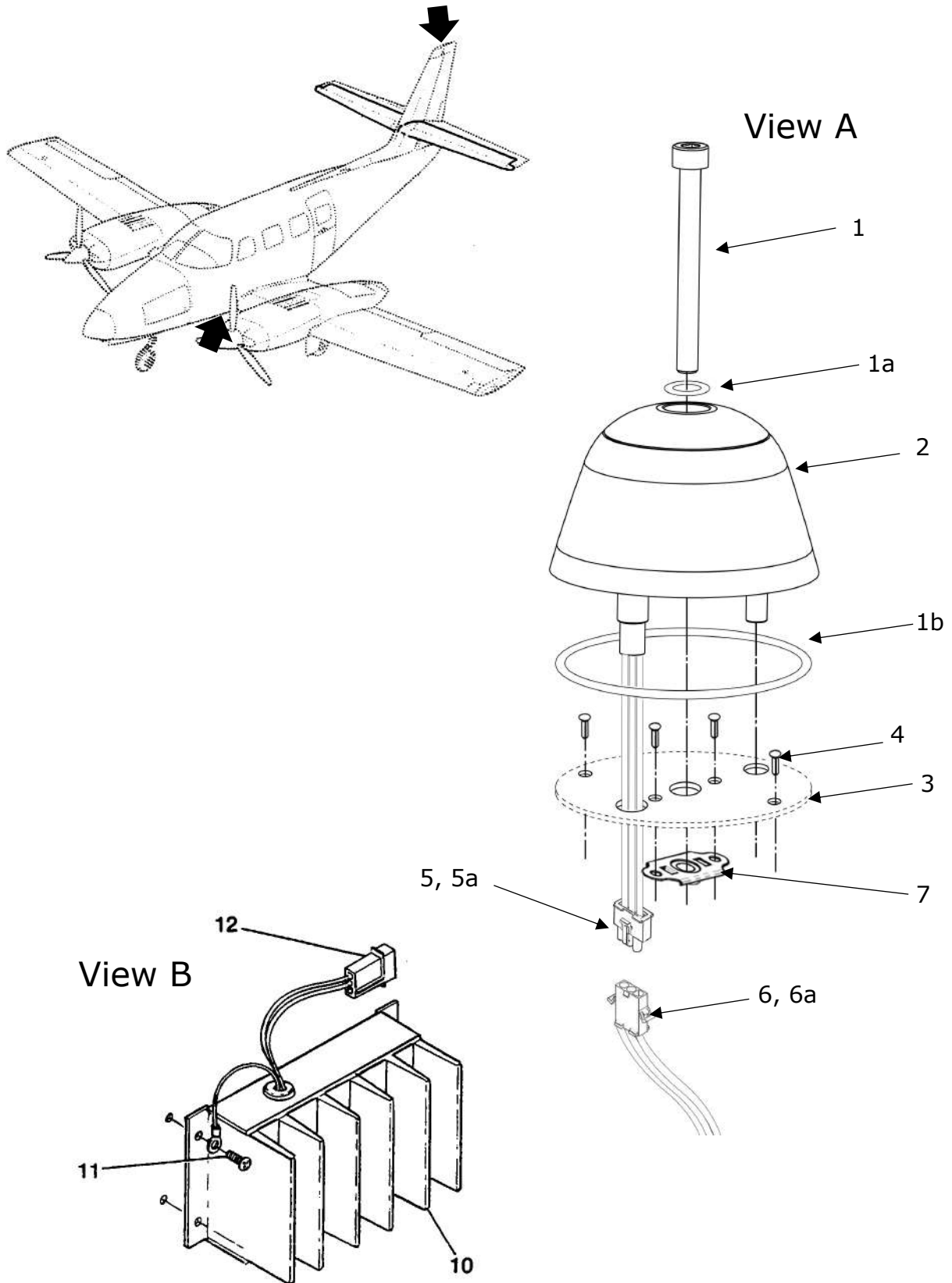

Figure and Index Number	Part Number	Description	Parts Avail.	QTY. Per assy.
View A		ANTI-COLLISION LIGHT INSTALLATION		
1	AVS-79840905050	Screw M5x50mm		1
1a	AVS-170299005	Flat Washer – Nylon		1
1b	AVS-OR05302N70-D0A	O-Ring		1
2	AVE-RBXPR-001	RedBaron XP Galactica		1
3	AVS-P00 0107409-A60	RedBaron XP Adapter		1
4	AVS-6252408	Rivet 2.4x8mm		4
5	03091031	3-Pole Connector – Male		1
5a	2092116	Pin		3
6	03092031	3-Pole Connector - Female		1
6a	2091117	Socket		3
7	AVS-KFL-M5-080	Floating Riveting Nut		1
View B		STROBE BOX REMOVAL		
10	C594502-0102	Flasher Assy		1
11	AN515-8R6	Screw		1
12	S1638-2	Housing Cap		1
NOTES				
<ol style="list-style-type: none"> <li>1. Remove flashing beacon in accordance to the aircraft maintenance manual.</li> <li>2. Disconnect the wire bundle from the flashing beacon</li> <li>3. Inspect the installation area for corrosion and correct according to AMM if required</li> <li>4. Splice the new light's wires into the bundle according to the referenced installation manuals and the common practice FAR AC 43.13-2B Chapter 4</li> <li>5. Install items 1 to 6 as described in view A. Drill hole to substructure for anti-rotation pin as required.</li> </ol>				

1.7 Taxi Light Installation – Nose Gear

Kit Number: C303-05

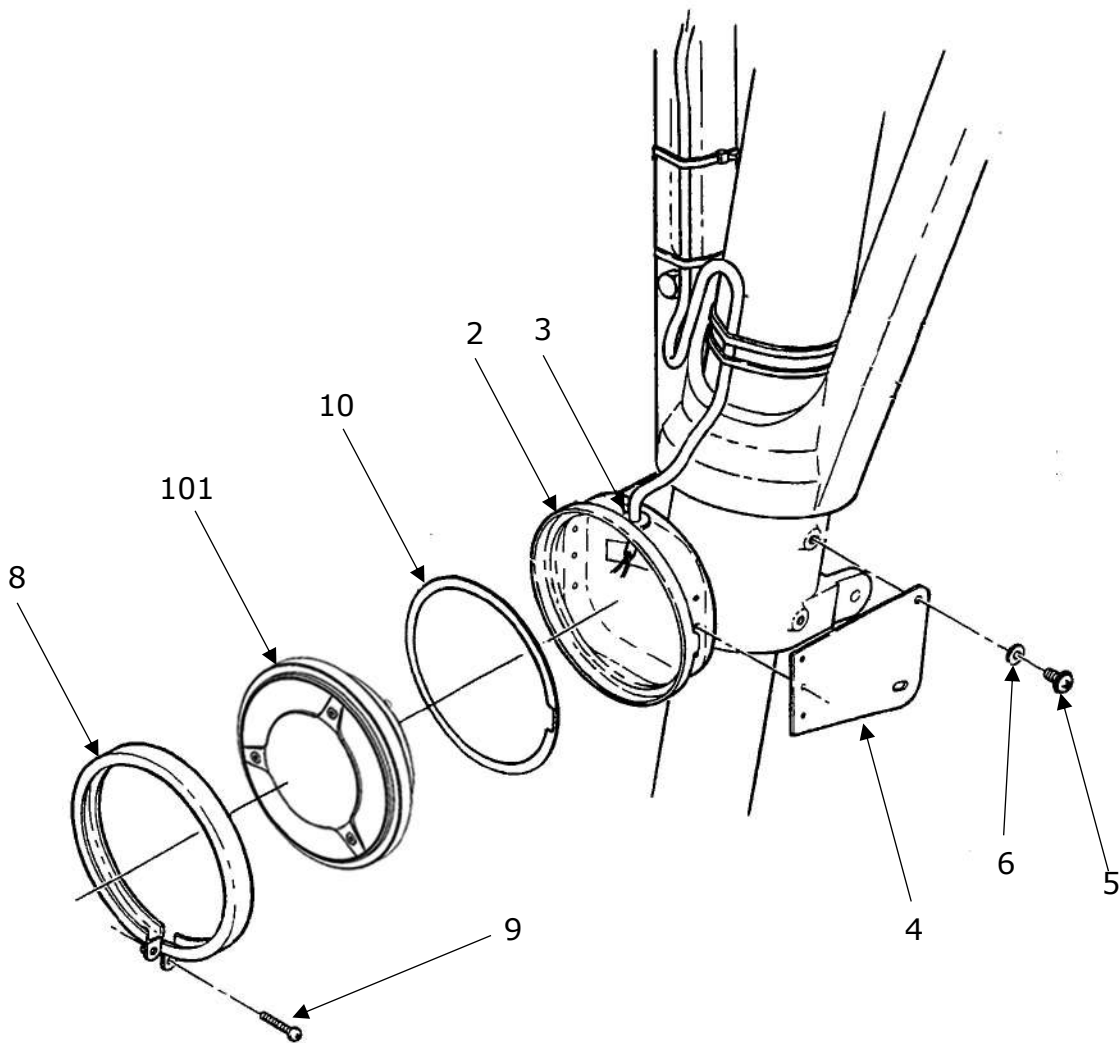
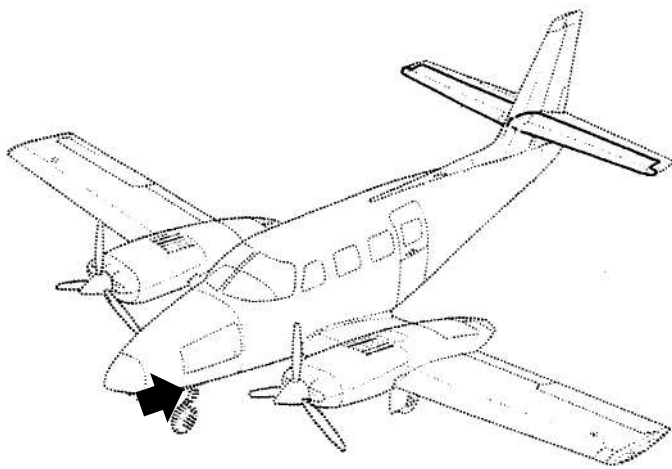

Figure and Index Number	Part Number	Description	Parts Avail.	QTY. Per assy.
101	AVE-H30TATSNT-T0A	Hercules Drop-In Taxi		1
	Original parts			
2	2543052-1	Housing Assy		1
3	MS35489-6	Grommet		1
4	2543051-1	Support		2
5	AN525-10R6	Screw		2
6	AN960-10	Washer		2
7	MS21209-F1-15	Insert		2
8	B4209	Retaining Ring Assy		1
9	MS35206-233	Screw		1
<b>NOTES</b> <ol style="list-style-type: none"> <li>1. Remove taxi light bulb in accordance to the Aircraft Maintenance Manual (AMM).</li> <li>2. Disconnect the wire bundle from the landing and taxi lights.</li> <li>3. Inspect the installation area for corrosion and correct according to AMM if required</li> <li>4. Install taxi light, item 101 using the original hardware as described and in accordance to the aircraft maintenance manual. Trim bracket, item 8, as necessary in case it is required for the adjustment of the light. Assure that corrosion protection is applied again per AMM.</li> <li>5. Connect the wires of the lights as per AMM and common practice. Regard lights polarity.</li> </ol>				

1.8 Landing Lights Installation

Kit Number: C303-06

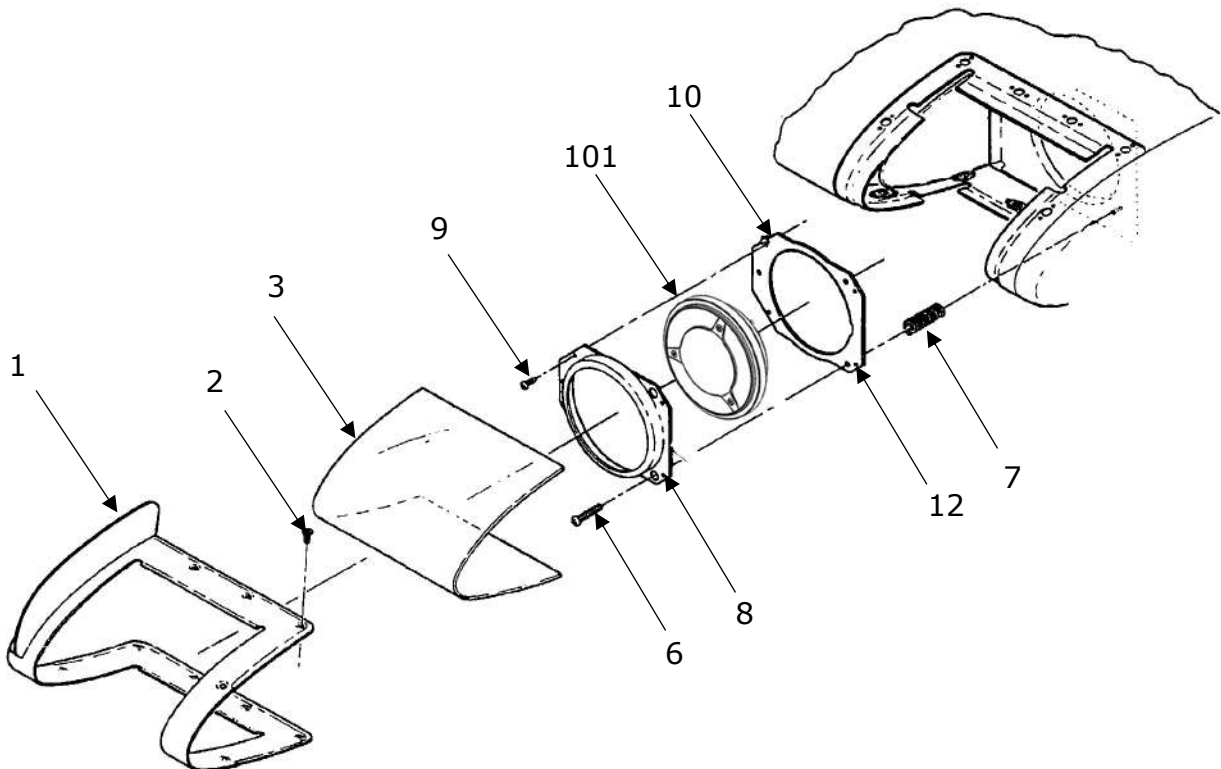
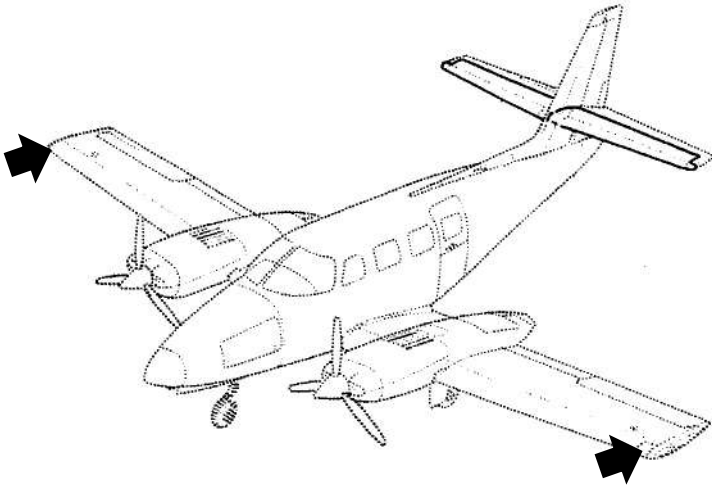

Figure and Index Number	Part Number	Description	Parts Avail.	QTY. Per assy.
101	AVE-H30TATSNL-T0A	Hercules Landing		2
	Original parts			
1	2522366-3	Retainer Assy – Landing Light LH		1
	2522366-4	Retainer Assy – Landing Light RH		1
2	S1022Z8-6	Screw		12
3	2522349-1	Lens – Landing Light LH		1
	2522349-2	Lens – Landing Light RH		1
4	2522350-1	Light Assy - Landing LH		1
5	2522350-2	Light Assy - Landing RH		1
6	AN520-10R20	Screw		3
7	0713124-1	Spring		3
8	2522346-1	Bracket		1
9	S1021Z6-8	Screw		4
10	NAS488-1-3	Nut		4
12	2522364-1	Plate		1

## NOTES

1. Remove landing light assy in accordance to the Aircraft Maintenance Manual (AMM).
2. Disconnect the wire bundle from the landing lights.
3. Inspect the installation area for corrosion and correct according to AMM if required
4. Install landing light, item 101 using the original hardware as described and in accordance to the aircraft maintenance manual. Trim bracket, item 8, as necessary in case it is required for the adjustment of the light. Assure that corrosion protection is applied again per AMM.
5. Splice the wires of the lights into the aircraft wiring as per AMM and common practice. Regard lights polarity.

## Part 2 Compliance demonstration

This document is in relation to the certification program AVE-MOD-033-PFC.  
The compliance is demonstrated for the following certification specification:

Requirements	MoC	Statement of Compliance
CS 23.2250 Design and construction principles	MoC 0	<p><b>CS 23.603</b>            (a) All materials used are common tested materials.            (b) No strength and other property data has been used for this modification.            (c) The environmental conditions have been regarded for the selection of materials and the surface treatment.</p>
CS 23.2260 Materials and processes	MoC 0	<p><b>CS 23.603</b>            (a) All materials used are common tested materials.            (b) No strength and other property data has been used for this modification.            (c) The environmental conditions have been regarded for the selection of materials and the surface treatment.</p> <p><b>CS 23.605</b>            (a) The fabrication methods for composite parts is defined in our POE.            (b) Is not applicable as the fabrication method is common knowledge and the parts are not load carrying.</p> <p><b>CS 23.613</b>            (a) to (e) Is not applicable as the parts are nonstructural. The design values used are very conservative and do not require a premium selection of the material. The materials are widely common materials with better properties than the original part. No failure can have a catastrophic consequence and the material also is not fatigue critical.</p>
CS 23.2335 Lightning protection	MoC 0	<p><b>CS 23.0867</b>            Specific PNs of the lights installed were not tested for lightning direct effects as per Section 23.0 of RTCA DO-160G, therefore compliance with paragraph 23.867 was not demonstrated in this project.</p> <p><b>CS 23.1365</b>            (a) The only additional wire to be installed is the synchronization wire which is only a signal wire and does not transfer power.            (b) The installed equipment is thermally protected.            (c) The additional wire is spliced to the light and therefore identified.            (d) The wire is to be installed along the existing wiring which is an approved location.            (e), (f) not applicable</p>

Requirements	MoC	Statement of Compliance
CS 23.2500 General requirements on systems and equipment function	MoC 0	<p><b>CS 23.1301</b>            (a) All navigation and anti-collision lights are ETSO certified. All landing lights are qualified according to RTCA DO160 as per AVE-H30-001-CCL.            (b) No changes are made which would require a changed or a new label. The equipment is labelled to be identified and with its limitation.            (c) All equipment is installed within their limits.            (d) The proper function is determined in a ground check as per MCS. The improved visibility had been demonstrated in document AVE-MOD-004-SR.</p> <p><b>CS 23.1309</b>            (a) All products have been tested to the appropriate environmental standard. In addition to that improves the new light installation the mean time between failure by a factor of about 1000. All lights are brighter at lower power consumption and a much lower temperature.</p>
CS 23.2625 Instructions for Continued Airworthiness	MoC 0	<p><b>CS 23.1529</b>            The modification includes a supplement to the King Air 200 &amp; 300 Aircraft Maintenance Manual (AMM) modified by the AMM Supplement.</p>