



INSTALLATION MANUAL

Exceleron DayLite

DOC.NO:AVE-EX9-IM

© Aveo Engineering Group, s.r.o. All rights reserved. The information contained within this document must not be disclosed, copied or reproduced in whole or in part without prior written permission from Aveo Engineering Group, s.r.o. Distribution of this document shall only be as stated in Table 02 unless otherwise agreed by Aveo Engineering Group, s.r.o.

Table of Contents

PART 0	MANUAL ADMINISTRATION	3
0.1	DOCUMENT APPROVAL	3
0.2	AMENDMENT RECORD PROCEDURE	4
0.3	AFFECTED PAGES PROCEDURE.....	4
PART 1	INSTALLATION DATA	5
1.1	EXCELERON DAYLITE	5
1.2	OPERATING INSTRUCTIONS	5
1.3	INSTALLATION SCHEMATIC / WIRING DIAGRAM	5
1.4	CONTROL & POWER INPUTS	5
1.5	TECHNICAL SPECIFICATION.....	6
1.6	TECHNICAL DRAWING	6
1.7	WIRING CHART	7
1.8	OPTIC SIMULATION.....	8
1.9	EQUIPMENT LIMITATION.....	11
1.10	CARE AND CLEANING OF LIGHTS	11
1.11	TESTING THE LIGHTS BEFORE INSTALLATION	11
1.12	NOTES ON INSTALLATION	12
1.13	CONTINUED AIRWORTHINESS INFORMATION	12
1.14	ROHS COMPLIANCE STATEMENT	13
1.15	EU REACH REGULATION (EC) No. 1907/2006.....	13

Part 0 Manual Administration

0.1 Document approval

This document has been established in accordance with an alternative procedure to DOA approved under EASA AP429.

This installation manual is applicable for part numbers:

- Exceleron DayLite Landing (9°) **AVE-EX9LW-D01**
- Exceleron DayLite Landing (12°) **AVE-EX9LW-D02**
- Exceleron DayLite Landing (9x10.5°) **AVE-EX9LW-D03**
- Exceleron DayLite Landing (9x10°) **AVE-EX9LW-D04**
- Exceleron DayLite Taxi (12x30°) **AVE-EX9TW-D01**
- Exceleron DayLite Taxi (20°) **AVE-EX9TW-D02**

Compiled by: _____ 04. – May - 2021

Petr Jaroš
Engineer, Aveo Engineering Group, s.r.o.

Approved by: _____ 04. – May - 2021

Georg Hartl
Head of DO, Aveo Engineering Group, s.r.o.

0.2 Amendment Record procedure

The master copy of this document shall be kept electronically as a read only document under the control of Aveo Engineering Group, s.r.o. as Master Copy.

ALL amendments to this manual will initiate a raise of issue.

ALL raises of issue will be given a sequential Alphabetic Issue Ident sequentially from 01 to 99 in Table 01 - **Issue No:** Column– Initial Issue of Document will be **"01"**

ALL Issues of this document will be approved by Head of DO

Issue No.	Details	Date	Affected Pages
01	Initial Issue	04.May.2021	ALL
Table 01: Document Amendment Record Table			

0.3 Affected Pages Procedure

ALL pages affected by ANY raise of issue of this document will be listed in Table 01 - *Affected Pages* Column.

The reason(s) for ALL raise of issue and description of change due to raise of issue will be provided for ALL raises of issue in Table 01 - *Details* Column.

Changes from the previous issue are highlighted by **YELLOW HIGHLIGHTING** over new content. AND **YELLOW HIGHLIGHTING** AND CROSSING OUT of deleted content.

Example (~~CROSSING OUT~~)

Part 1 Installation data

1.1 Exceleron DayLite

The Exceleron DayLite™ landing or taxi light is a high powered LED light use in GA and transport category aircraft. It has been designed to be lightweight and with a low power draw to meet the highest requirements of all certified aircraft.

- Exceleron DayLite Landing (9°) **AVE-EX9LW-D01**
- Exceleron DayLite Landing (12°) **AVE-EX9LW-D02**
- Exceleron DayLite Landing (9x10.5°) **AVE-EX9LW-D03**
- Exceleron DayLite Landing (9x10°) **AVE-EX9LW-D04**
- Exceleron DayLite Taxi (12x30°) **AVE-EX9TW-D01**
- Exceleron DayLite Taxi (20°) **AVE-EX9TW-D02**

1.2 Operating Instructions

When installed on the aircraft, using the aircraft's power (14 or 28 volts), the light will be at its maximum intensity. *Operating Voltage range is 9-36VDC.*

1.3 Installation Schematic / Wiring Diagram

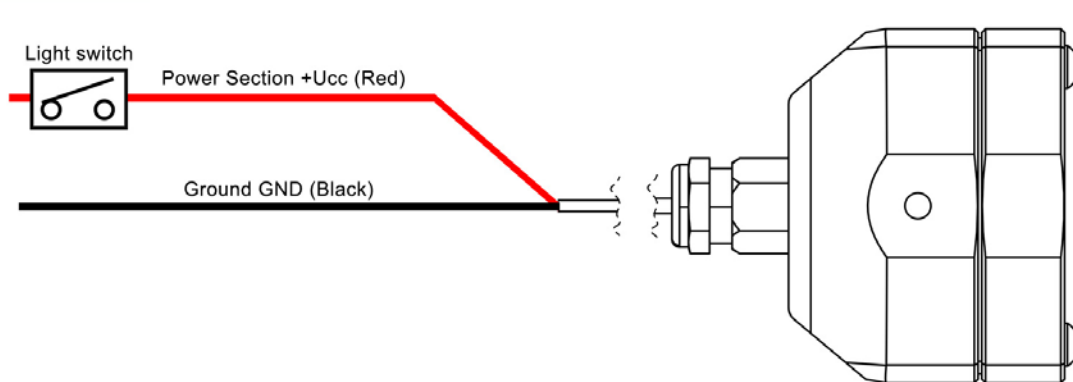

Recommended wire AWG size: **22**

1.4 Control & Power Inputs

- BLACK** Negative common power supply line (ground)
- RED** Positive power supply line

1.5 Technical Specification

Electronic specification - Ambient temperature (25°C):

Operating voltage:	9-36V DC
Voltage protection:	a. Over-voltage protection: 80V/1s b. Over-voltage lockout: 38.5V c. Under-Voltage protection: 7V
Reverse polarity protection:	Yes
LED quantity:	6 pcs
Performance:	
Input current:	2.13A @14V DC 1.06A @28V DC
Input power:	29.8W @14V DC 29.8W @28V DC
Operating temperature:	-55°C to +85°C / -67°F to +185°F
Over-Temperature protection:	Yes
Weight:	7.936 oz (225 g)

1.6 Technical Drawing

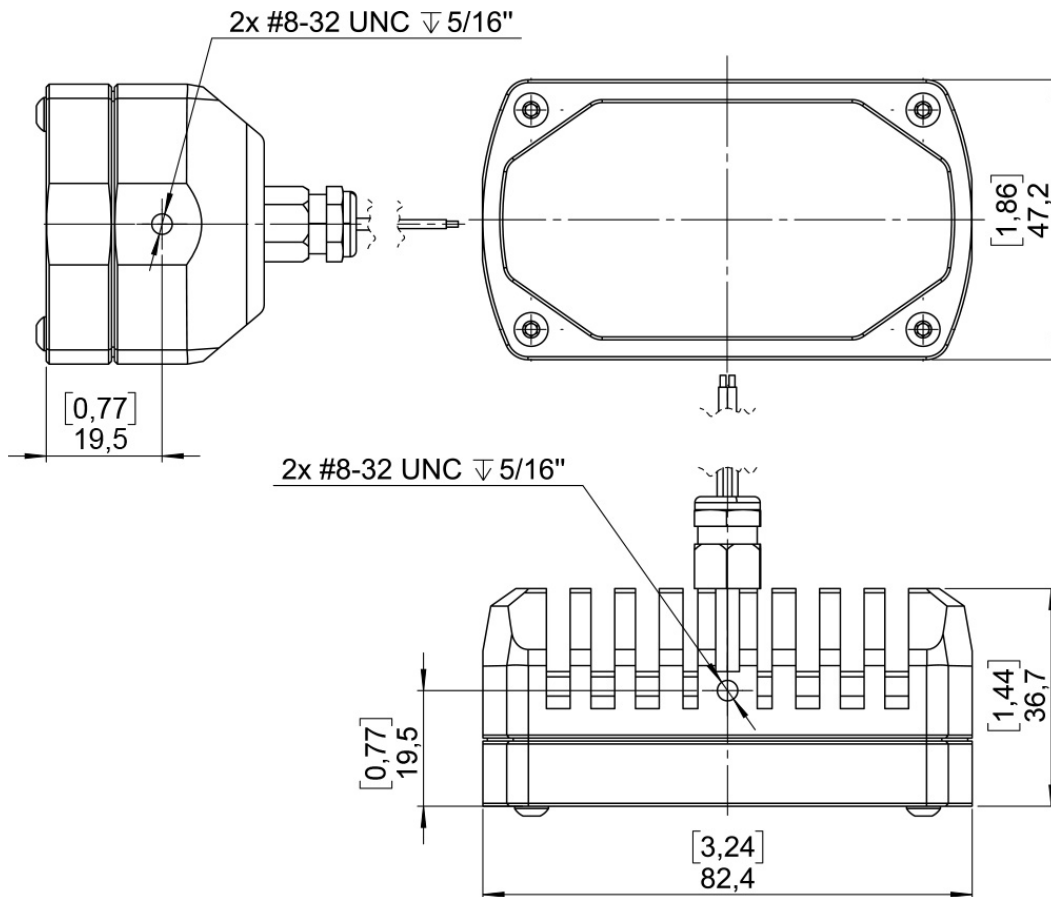

*dimensions in mm [inches]

1.7 Wiring Chart

Use diagram below defining the wiring size depending on the current and the wire length. Make sure you add up the current for all connected lights. If current is not given, then divide the power by the voltage.

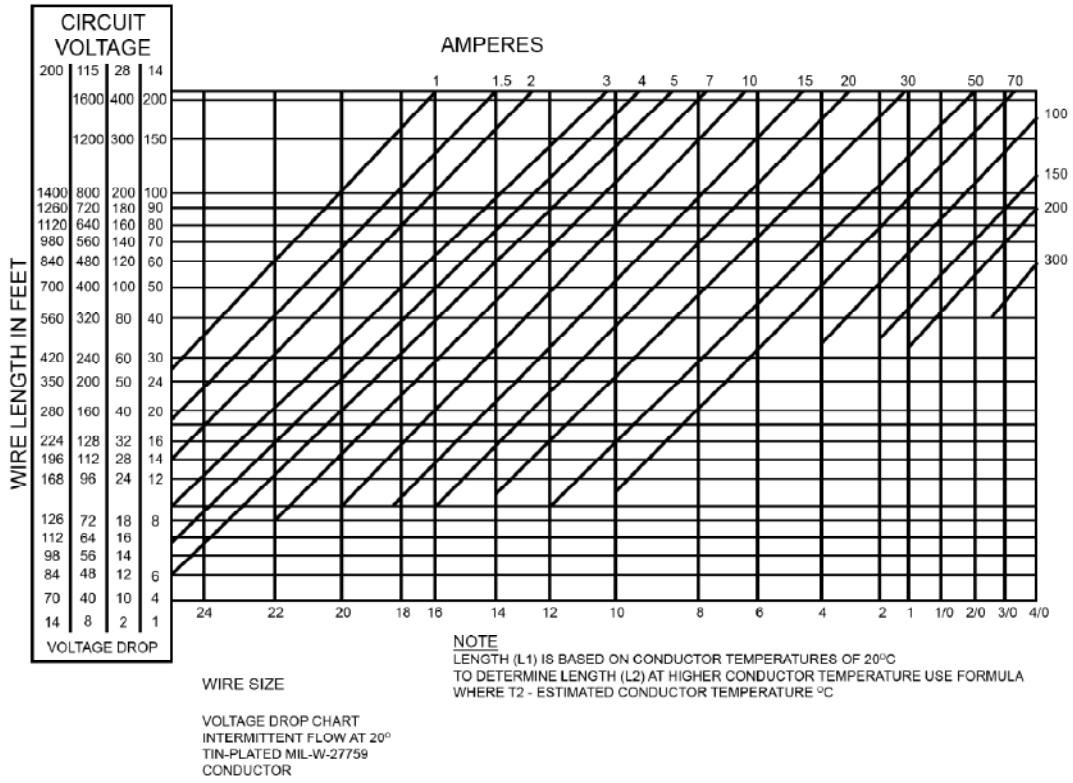

1.8 Optic Simulation

Exceleron DayLite LANDING (9°)

PN: AVE-EX9LW-D01

110 000 cd

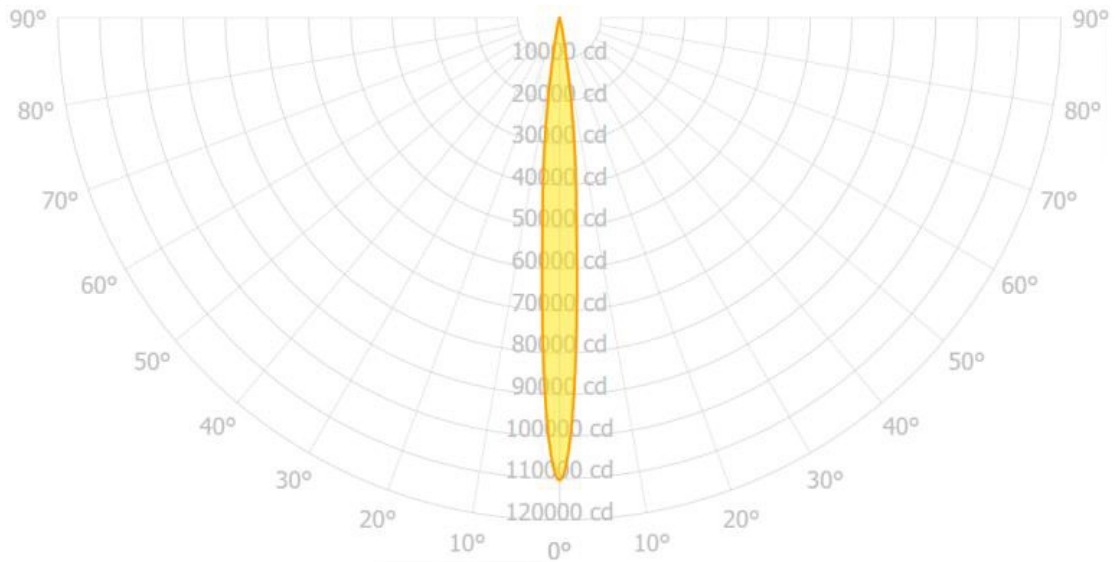

Exceleron DayLite LANDING (12°)

PN: AVE-EX9LW-D02

63 000 cd

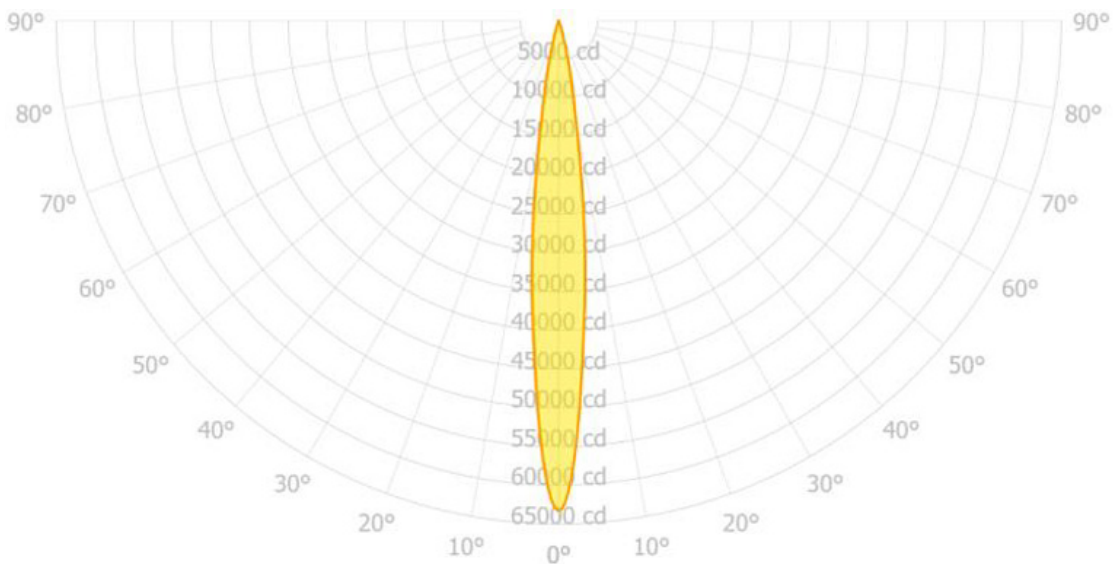

Exceleron DayLite LANDING (9x10.5°)

PN: AVE-EX9LW-D03

66 000 cd

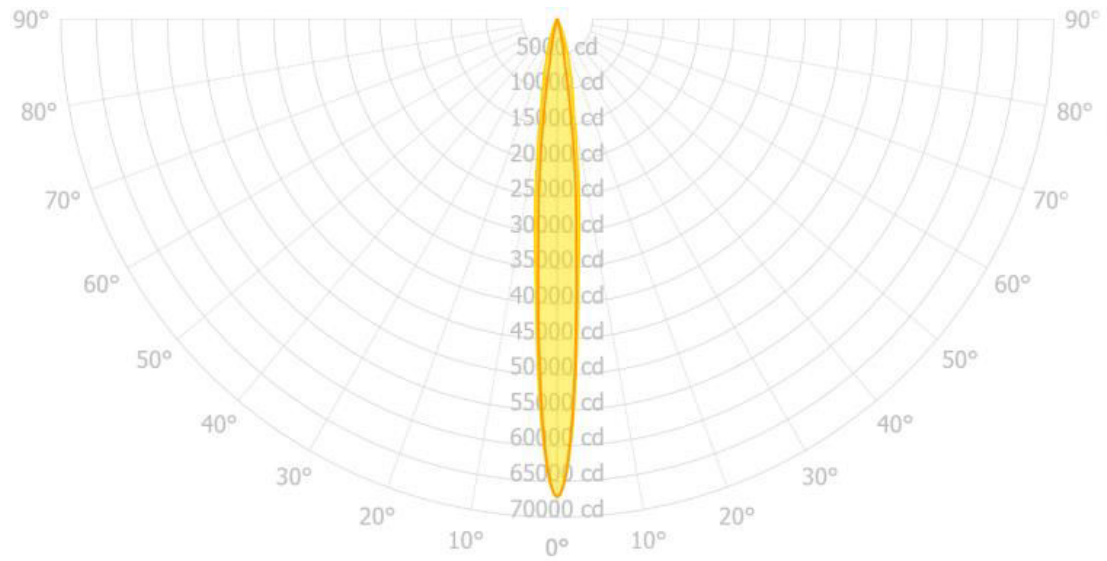

Exceleron DayLite LANDING (9x10°) PN: AVE-EX9LW-D04

80 000 cd

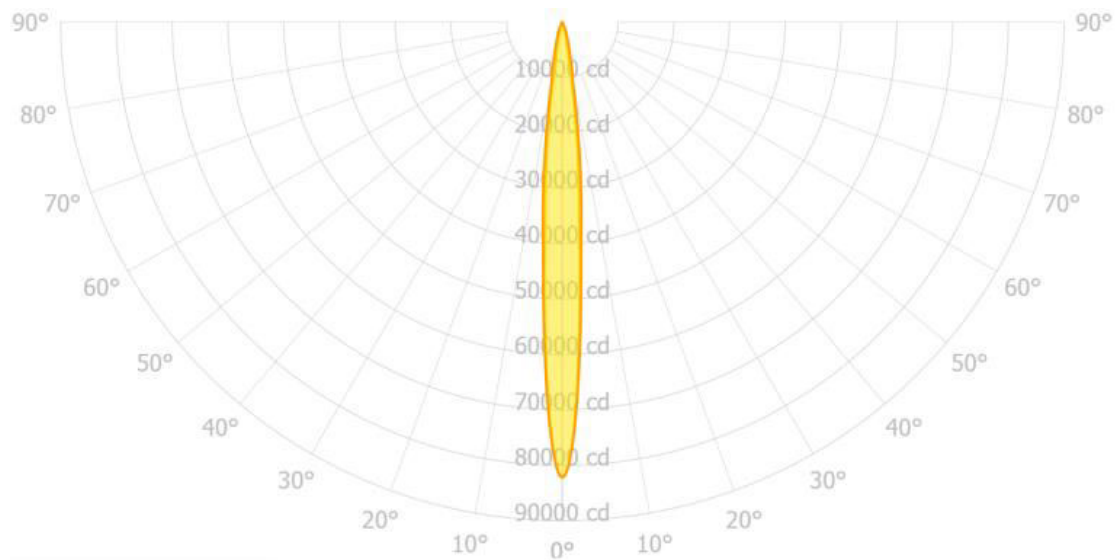

Exceleron DayLite TAXI (12x30°) PN: AVE-EX9TW-D01

24 000 cd

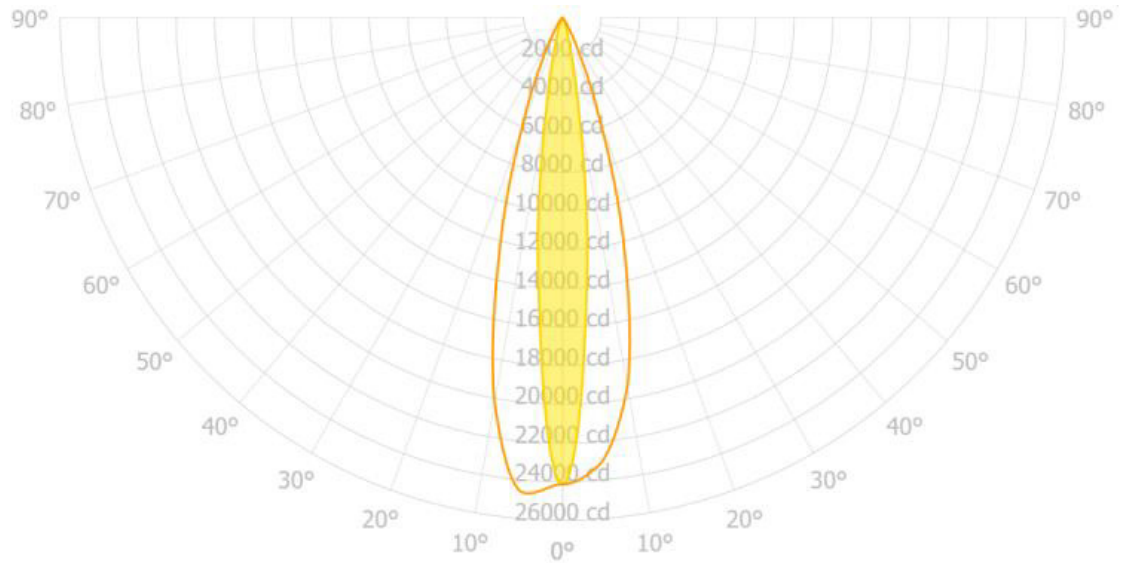

Exceleron DayLite TAXI (20°) PN: AVE-EX9TW-D02

31 000 cd

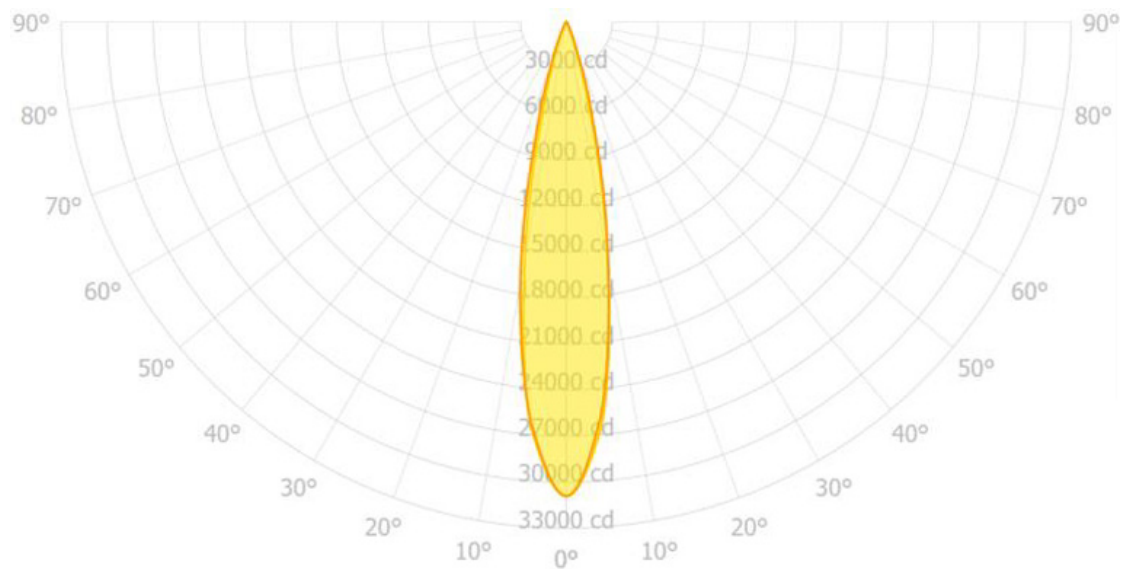

1.9 Equipment Limitation

Exceleron DayLite™ should only be powered by 9-36VDC.

1.10 Care and Cleaning of Lights

Aveo Engineering Aviation Lights are factory polished and delivered as ready to install on the aircraft.

If the lights need a deeper cleaning, they should be polished with a quality lamb's wool sheet that is suitable also for deeper polishing. Under no circumstances should any petroleum based product be used to clean the lights.

1.11 Testing the Lights before Installation

All Aveo Aviation lights undergo rigorous testing prior to being released from our engineering manufacturing department. This testing involves a burn-in time as well as other function testing. No light is released for sale without undergoing this extensive operational testing.

When you receive the *Exceleron DayLite* light, and wish to test the function of the light prior to installation on your aircraft, please observe the following procedure:

1. Review the written information that is enclosed in the packaging. Warranty information as well as a cautionary note about power supply removal is enclosed in each package.
2. Remove the light from the package.

Note that there are two wires:

Red	Positive power supply line
Black	Negative power supply line

3. Testing the function of the light can be accomplished using a regular 14V/10A DC or 28V/5A DC power supply (not a battery charger).

Connect the black wire to the ground (negative) leads of a power supply, then connect the red wire to the positive (+) leads on the power supply. The light should start lighting.

When installed on the aircraft and using the aircraft's power (14 or 28 volts), the light will be at its maximum intensity.

If the tests are successfully completed, the lights can be installed on the aircraft.

IMPORTANT NOTES:

Under no circumstances should any power supply other than a 9-36V DC, or a 14 or 28 Volt battery be used to test the light. Do not use: Battery chargers, battery back-up power devices, or other bench avionics testing methods to test the aviation light. The light is functional between 9 and 36 volts. Use of a battery charger or other power unit to test the light will void the warranty and may damage the light.

If you have any questions about the installation of the lights, please refer to our web site: www.aveoengineering.com.

1.12 Notes on Installation

Stainless steel screws SHCS #8-32 UNC or equivalent mounting screws are recommended to be used for installation. Screw length depends on placement of screws on aircraft.

Spread the tightening forces evenly around the mounting hole.

1.13 Continued Airworthiness Information***Periodic Inspection Procedure for Exceleron DayLite.***

The **Exceleron DayLite** light should always be checked for proper operation during preflight. This procedural information is already provided in all general aviation aircraft flight manuals.

The lights should be visually inspected for general condition, proper operation, and correct installation at each annual and/or 100 hours inspection. In addition refer to section 1.10 of installation manual for detailed cleaning instructions.

1.14 RoHS Compliance Statement

Scope

This statement clarifies Aveo Engineering's compliance with European Union Directive 2015/863/EU on the restriction of the use of certain hazardous substances in electrical and electronic equipment ("RoHS") that took effect on June 4, 2015. The RoHS Directive restricts the sale of electronic equipment containing certain hazardous substances in the European Union including:

Cadmium(Cd): 0.01%

Mercury: 0.1%

Lead(Pb) : 0.1%

Hexavalent chromium (Cr6+) : 0.1%

Polybrominated biphenyls (PBB): 0.1 %;

Polybrominated diphenyl ethers (PBDE): 0.1 %

Bis(2-Ethylhexyl) phthalate (DEHP): 0.1% (added in 2015);

Benzyl butyl phthalate (BBP): 0.1% (added in 2015);

Dibutyl phthalate (DBP): 0.1% (added in 2015);

Diisobutyl phthalate (DIBP): 0.1% (added in 2015)

Compliance

Aveo Engineering certifies that all products sourced from manufacturing facilities comply with the environmental standards set forth by the Directive 2015/863/EU, recast amendment of RoHS Directive 2011/65/EU Article (4), and do not contain any of the above-mentioned, 10 hazardous substances above the specified limits. All products manufactured by Aveo Engineering are RoHS-compliant. With regards to RoHS-2 CE marking, product packaging is labeled attesting conformity if required.

References

Directive 2015/863/EU of the European Parliament and of the Council on the restriction of the use of certain hazardous substances in electrical and electronic equipment.

1.15 EU REACH Regulation (EC) No. 1907/2006

Aveo Engineering declares that no chemicals are produced and that none of the chemicals used during the production process or needed for the product maintenance or service, is listed on the current European Chemicals Agency's Candidate list of Substances of Very High Concern for Authorization.