



INSTALLATION MANUAL

EyeBeam VIP

DOC.NO: AVE-EBILMV-IM

Table of Contents

PART 0	MANUAL ADMINISTRATION	3
0.1	DOCUMENT APPROVAL	3
0.2	AMENDMENT RECORD PROCEDURE	4
0.3	EFFECTED PAGES PROCEDURE	4
PART 1	INSTALLATION DATA	5
1.1	PRODUCT INFORMATION	5
1.2	OPERATING INSTRUCTIONS	6
1.3	INSTALLATION SCHEMATIC / WIRING DIAGRAM	7
1.4	CONTROL & POWER INPUTS.....	8
1.5	TECHNICAL SPECIFICATION	9
1.6	TECHNICAL DRAWING	10
1.7	WIRING CHART	11
1.8	OPTIC SIMULATION.....	12
1.9	EQUIPMENT LIMITATION.....	12
1.10	CARE AND CLEANING OF YOUR AVEO ENGINEERING AVIATION LIGHTS.....	12
1.11	TESTING OF THE LIGHT BEFORE INSTALLATION	12
1.12	NOTES ON INSTALLATION	13
1.13	CONTINUES AIRWORTHINESS INFORMATION	14
1.14	ROHS COMPLIANCE STATEMENT	14
1.15	EU REACH REGULATION (EC) No. 1907/2006.....	15

Part 0 Manual Administration

0.1 Document Approval

This document has been established in accordance with an alternative procedure to DOA approved under EASA AP429.

This installation manual is applicable for part numbers:

- EyeBeam VIP Custom **AVE-EBILMW-TA1**
- EyeBeam VIP Black Pearl SB **AVE-EBILMW-TA2**
- EyeBeam VIP **AVE-EBILMW-TV1**

Compiled by: _____ 11 October 2024

Petr Jaroš
Engineer, Aveo Engineering Group, s.r.o.

Approved by: _____ 11 October 2024
Georg Hartl
Head of DO, Aveo Engineering Group, s.r.o.

0.2 Amendment Record Procedure

The master copy of this document shall be kept electronically as a read only document under the control of Aveo Engineering Group, s.r.o. as Master Copy.

ALL amendments to this manual will initiate a raise of issue.

The original issue will be identified by "01", and subsequent issues will be numbered sequentially from 02 to 99 in Table 01 - **Issue No.** column.

ALL issues of this document will be approved by Head of DO.

Issue No.	Details	Date	Affected Pages
01	Initial Issue	24July.2024	ALL
02	Added new Part Numbers Functions Update Wiring Diagram Update Control & Power Inputs Update DO160 Test Addition Technical Drawing Update	11 October 2024 2024	ALL 6 7 8 9 10
Table 01: Document Amendment Record Table			

0.3 Effected Pages Procedure

ALL pages affected by ANY raise of issue of this document will be listed in Table 01 - **Effected Pages** Column.

The reason(s) for **EACH** raise of issue and the description of respective change will be provided in Table 01 - **Details** Column.

Changes from the previous issue are shown as follows:

- a) new text is highlighted with yellow shading: **new**
- b) deleted text is shown with yellow shading and a strike through: ~~deleted~~

Part 1 Installation Data

1.1 Product information

EyeBeam VIP is tiltable dimmable cockpit map or reading light.

- **EyeBeam VIP Custom**
(Nickel Satin Brushed Finish)

AVE-EBILMW-TA1



- **EyeBeam VIP Black Pearl SB**
(Black Pearl Saint Brushed Finish)

AVE-EBILMW-TA2



- **EyeBeam VIP**
(Natural anodizing)

AVE-EBILMW-TV1



1.2 Operating Instructions

Operating Voltage range is 9-36VDC. When installed on the aircraft, using the aircraft's power (14 or 28 volts), the light will be at its maximum intensity.

**PN: AVE-EBILMW-TA1
AVE-EBILMW-TA2**

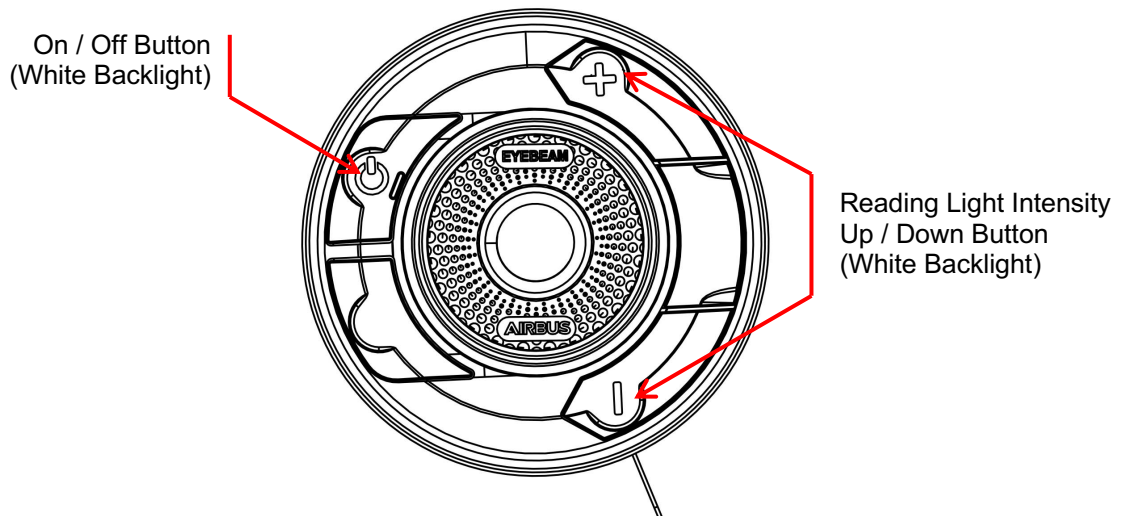

PN: AVE-EBILMW-TV1

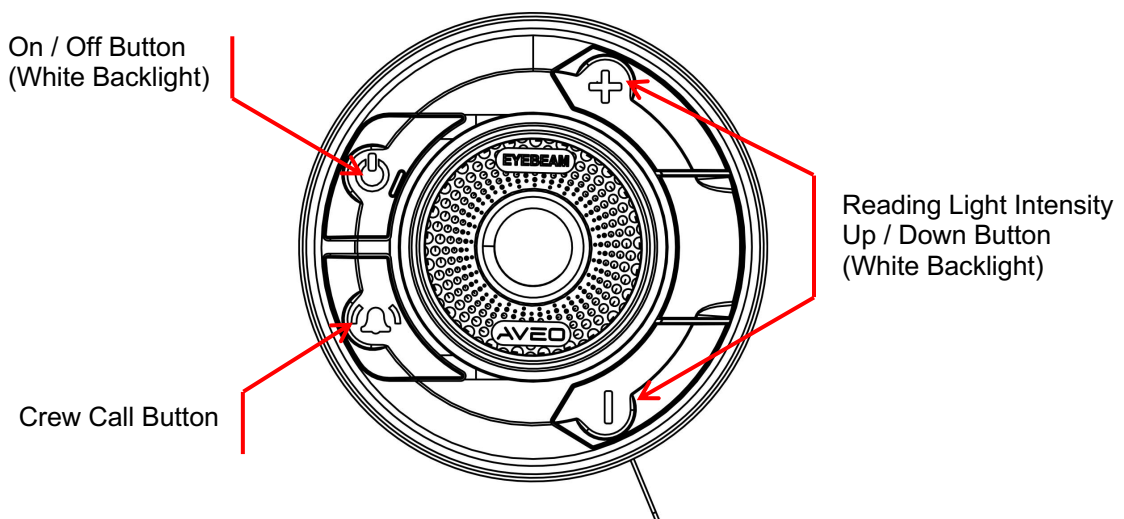

1.3 Installation Schematic / Wiring Diagram

PN: AVE-EBILMW-TA1
AVE-EBILMW-TA2

Main Power Leads
9-36 VDC

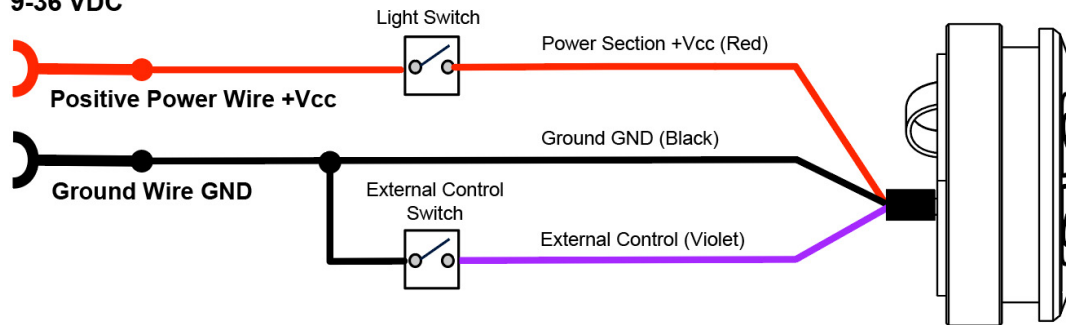

PN: AVE-EBILMW-TV1

Main Power Leads
9-36 VDC

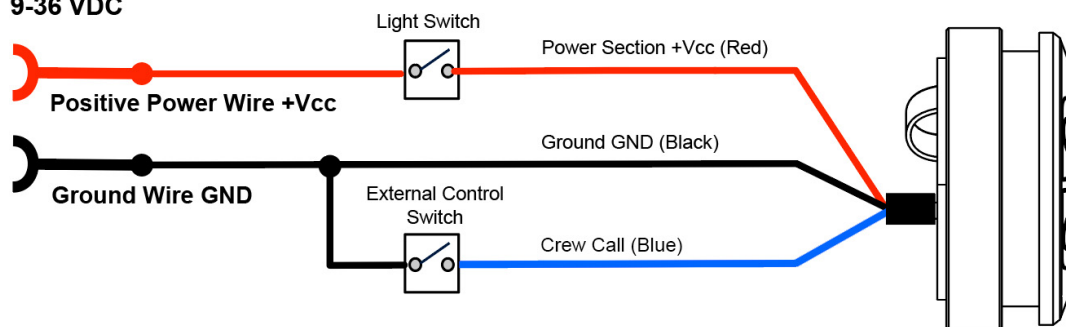

1.4 Control & Power Inputs

Pigtail length: 254 mm / 10"
End of the supplied pigtail is 5mm stripped wire, no coating
Wire size: AWG 22

PN: AVE-EBILMW-TA1
AVE-EBILMW-TA2

BLACK – Negative power supply line (ground)
RED – Positive power supply line
VIOLET – External control

External control function (violet):

1. Connecting violet wire to GND turns the light ON:
 - 1.1 LIGHT turns the DIM Mode 1 (100%) - FULL Brightness
 - 1.2 Then user can change light intensity ("+" or "-"):
DIM 100 % -> DIM 80 % -> DIM 60 % -> DIM 40 % -> DIM 20 % -> DIM 100 % -> DIM 80 % -> ...
2. Disconnecting violet wire from GND turns the LIGHT OFF (light on only backlight buttons)

PN: AVE-EBILMW-TV1

BLACK – Negative power supply line (ground)
RED – Positive power supply line
BLUE – Crew Call

1.5 Technical Specification

Electronic specification - Ambient temperature (25°C):

Dimensions:	See Section 1.6	
Weight:	120 g / 4.233 oz	
Operating Voltage Range:	9 – 36 VDC	
Input Current:	@28VDC	@14VDC
- full	80.6 mA	118.9 mA
- DIM 80%	69.0 mA	98.3 mA
- DIM 60%	57.7 mA	78.5 mA
- DIM 40%	46.8 mA	59.8 mA
- DIM 20%	36.6 mA	42.6 mA
Input Power:	@28VDC	@14VDC
- full	2.3 W	1.7 W
- DIM 80%	1.9 W	1.4 W
- DIM 60%	1.6 W	1.1 W
- DIM 40%	1.3 W	0.8 W
- DIM 20%	1.0 W	0.6 W
Ambient Temperature:	from -40°C to +85°C from -40°F to +185°F	
Beam angle:	47°	
Tilting:	+ / - 10°	

DO160G Test qualified:

Environment	Section	Category
Temperature / Altitude	4	F2
Temperature Variation	5	A
Humidity	6	A
Operational Shock and Crash Safety	7	B*
Vibration	8	U curve G S curve C
Sand and dust	12	D
Fungus	13	F
Salt Spray	14	T
Magnetics Effects	15	Z
Power Input	16	ZZX
Voltage Spike	17	A
Audio Freq. Conducted Susceptibility	18	Z
Induced Signal Susceptibility	19	BW
Radiated and Conducted Susceptibility	20	SS
Radiated and Conducted Emissions	21	H
Lightning Induced Transient Susceptibility	22	A2E2X
Electrostatic Discharge	25	A

* Aircraft Type: 5. Helicopters and All Fixed-wing, Test Type R, 20.0g all direction

1.6 Technical Drawing

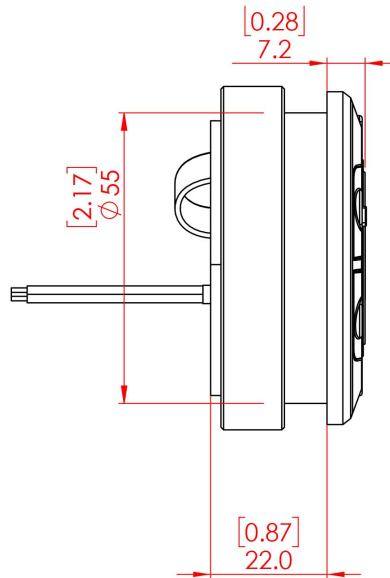

PN: AVE-EBILMW-TA1
AVE-EBILMW-TA2

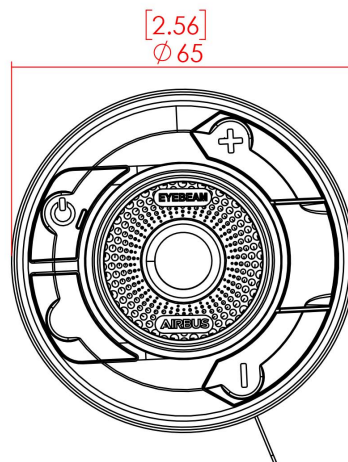

PN: AVE-EBILMW-TV1

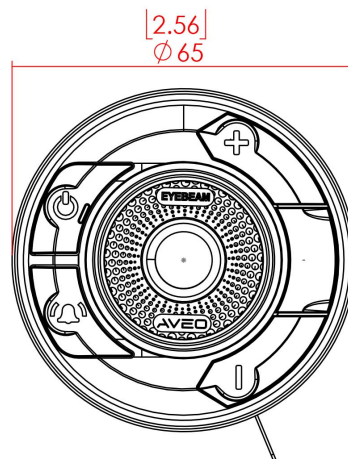

MOUNTING HOLE

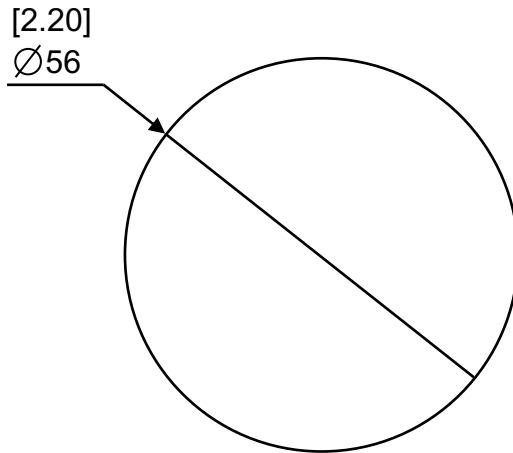

*Dimensions in mm [inches]

1.7 Wiring Chart

Use diagram below defining the wiring size depending on the current and the wire length. Make sure you add up the current for all connected lights. If current is not given, then divide the power by the voltage.

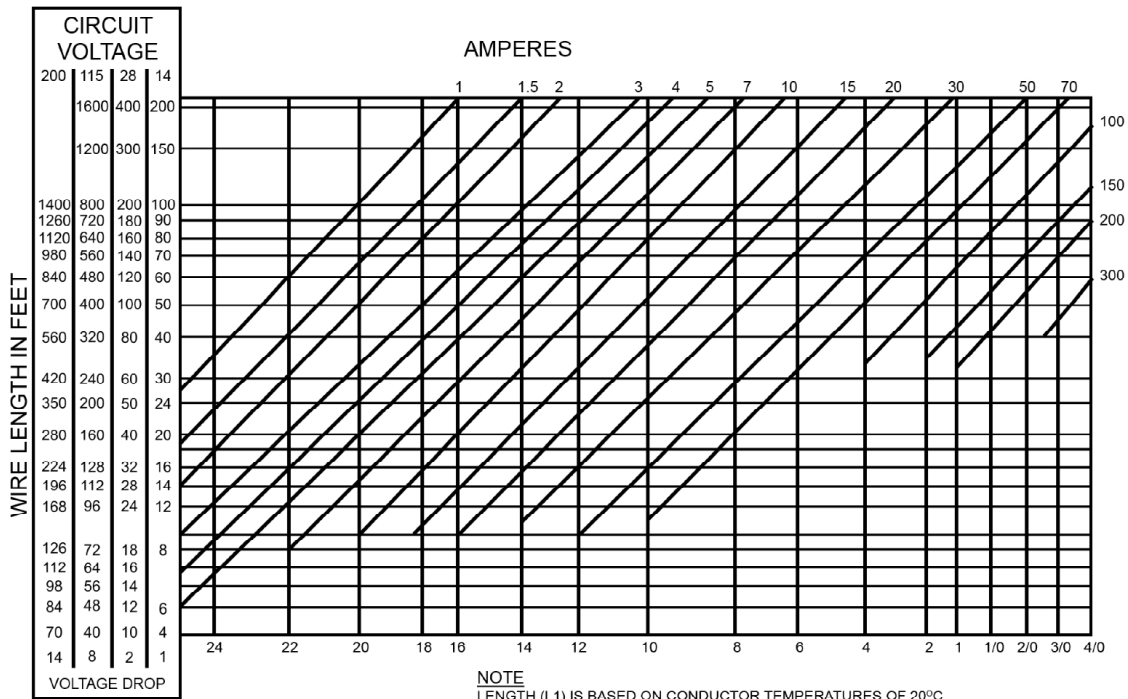

VOLTAGE DROP CHART
INTERMITTENT FLOW AT 20°
TIN-PLATED MIL-W-27759
CONDUCTOR

1.8 Optic Simulation

Light intensity Approx.	
Measured distance: 0.5m	
Mode 1 (100%)	700 lx
Mode 2 (80%)	580 lx
Mode 3 (60%)	470 lx
Mode 4 (40%)	350 lx
Mode 5 (20%)	250 lx

1.9 Equipment Limitation

EyeBeam VIP should only be powered by 9-36VDC.

1.10 Care and Cleaning of your Aveo Engineering Aviation Lights

When you receive your Aveo Engineering Aviation Lights, they will have been factory polished and ready to install on the aircraft.

If the lights require a deeper cleaning, they should be polished with a quality lamb's wool sheet and can also be used for deeper polishing. Under no circumstances should any petroleum based product be used to clean the lights.

1.11 Testing of the Light Before Installation

All Aveo Aviation lights undergo rigorous testing prior to being released from our engineering manufacturing department. This testing involves a burn-in time as well as other function testing. No light is released for sale without undergoing this extensive operational testing.

When you receive the **EyeBeam VIP** light, and wish to test the function of the light prior to installation on your aircraft, please note the following:

1. Please review the written information that is enclosed in the packaging. Warranty information as well as a cautionary note about power supply removal is enclosed with each package.
2. Remove the light from the package. Note that there are three (3) wires:

PN: AVE-EBILMW-TA1
AVE-EBILMW-TA2

Black	Negative lead
Red	Positive lead
Violet	External control

PN: AVE-EBILMW-TV1

Black	Negative lead
Red	Positive lead
BLUE	Crew Call

- Testing of the function of the light can be done with a regular 12V or 24V/5A dc power supply (not a battery charger). Connect the black wire to the ground (negative) leads of a power supply, and then connect the red wire to the positive (+) leads on the power supply. The EyeBeam VIP light should be in standby mode and ready for operations. When installed on the aircraft, using the aircraft's power (14 or 28 volts), the light will be at its maximum intensity.

After testing, the light can be installed on the aircraft.

IMPORTANT NOTES:

- Under no circumstances should any power supply other than a 9-36 VDC, or a 12 or 24 volt battery be used to test the light. Do not use: Battery chargers, battery back-up power devices, or other bench avionics testing methods to test the aviation light. The light is functional between 9 and 36 volts. Use of a battery charger or other power unit to test the light will void the warranty and may damage the light.

If you have any questions about the installation of the lights, please refer to our web site: www.aveoengineering.com

1.12 Notes on Installation

The components can be positioned in any orientation, however the EyeBeam's are to be positioned to project light as intended.

Mount EyeBeam VIP on the wall as it is described on the image below.

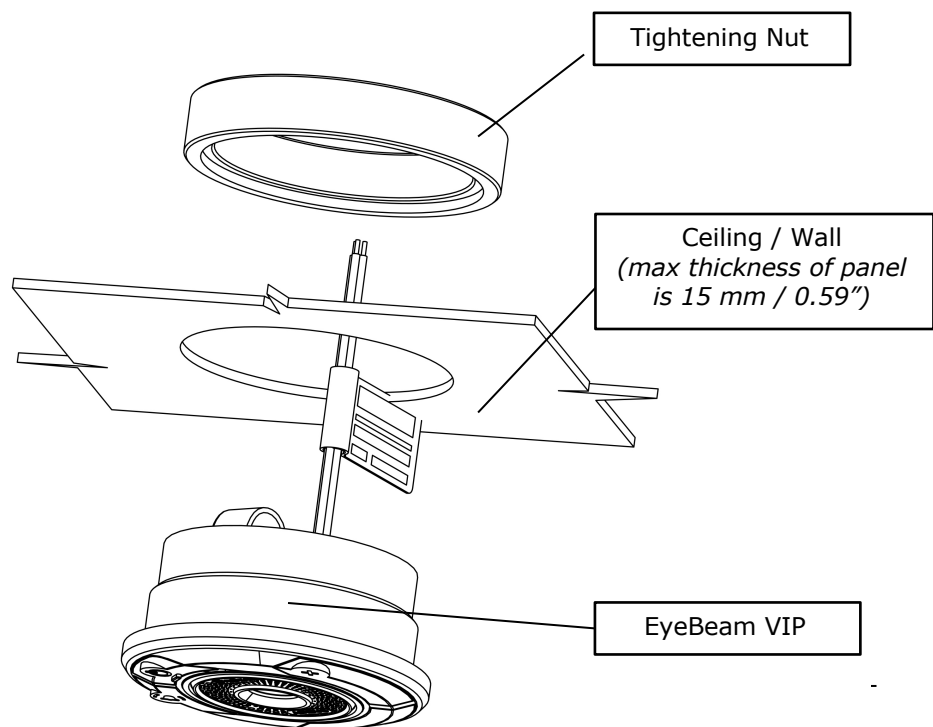

1.13 Continues Airworthiness Information

Periodic Inspection Procedure for EyeBeam VIP series.

The **EyeBeam VIP** lights should always be checked for proper operation during preflight. This procedural information is already provided in all general aviation aircraft flight manuals.

The lights should be visually inspected for general condition, proper operation, and correct installation at each annual and/or 100 hours inspection. In addition refer to section 1.10 of installation manual for detailed cleaning instructions.

1.14 RoHS Compliance Statement

Scope

This statement clarifies Aveo Engineering's compliance with European Union Directive 2015/863/EU on the restriction of the use of certain hazardous substances in electrical and electronic equipment ("RoHS") that took effect on June 4, 2015. The RoHS Directive restricts the sale of electronic equipment containing certain hazardous substances in the European Union including:

Cadmium(Cd): 0.01%

Mercury: 0.1%

Lead(Pb) : 0.1%

Hexavalent chromium (Cr6+) : 0.1%

Polybrominated biphenyls (PBB): 0.1 %;

Polybrominated diphenyl ethers (PBDE): 0.1 %

Bis(2-Ethylhexyl) phthalate (DEHP): 0.1% (added in 2015);

Benzyl butyl phthalate (BBP): 0.1% (added in 2015);

Dibutyl phthalate (DBP): 0.1% (added in 2015);

Diisobutyl phthalate (DIBP): 0.1% (added in 2015)

Compliance

Aveo Engineering certifies that all products sourced from manufacturing facilities comply with the environmental standards set forth by the Directive 2015/863/EU, recast amendment of RoHS Directive 2011/65/EU Article (4), and do not contain any of the above-mentioned, 10 hazardous substances above the specified limits. All products manufactured by Aveo Engineering are RoHS-compliant. With regards to RoHS-2 CE marking, product packaging is labeled attesting conformity if required.

References

Directive 2015/863/EU of the European Parliament and of the Council on the restriction of the use of certain hazardous substances in electrical and electronic equipment.

1.15 EU REACH Regulation (EC) No. 1907/2006

Aveo Engineering declares that no chemicals are produced and that none of the chemicals used during the production process or needed for the product maintenance or service, is listed on the current European Chemicals Agency's Candidate list of Substances of Very High Concern for Authorization.